

TECHNICAL MANUAL

OPERATOR'S, UNIT, AND
DIRECT SUPPORT
MAINTENANCE MANUAL
INCLUDING REPAIR PARTS
AND SPECIAL TOOLS LIST

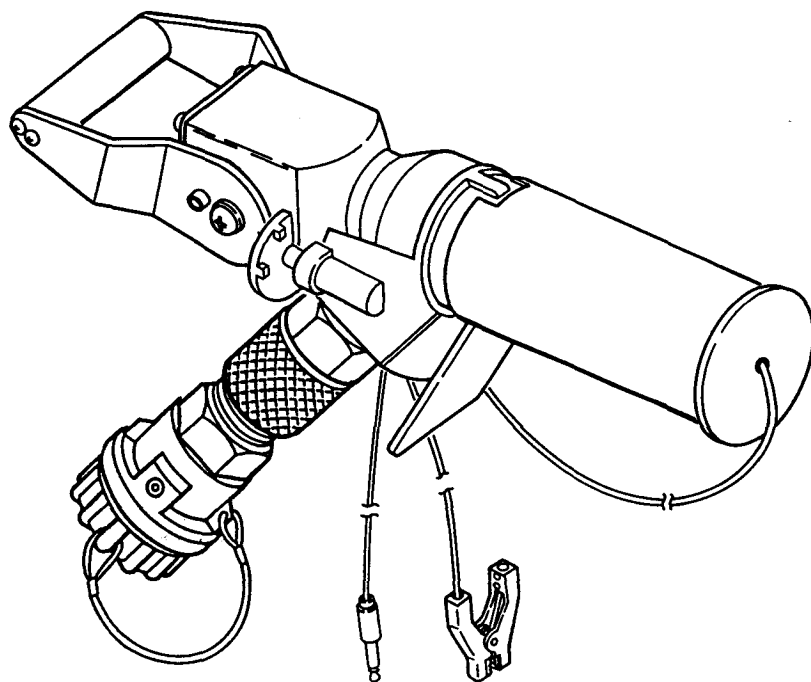

**CLOSED-CIRCUIT
REFUELING NOZZLE
ASSEMBLY
MODEL 64017B
(NSN: 4930-01-383-9467)**

OPERATING INSTRUCTIONS	2-1
---------------------------	-----

UNIT MAINTENANCE	4-1
---------------------	-----

UNIT TROUBLESHOOTING	4-3
-------------------------	-----

DIRECT SUPPORT MAINTENANCE	5-1
----------------------------------	-----

DIRECT SUPPORT TROUBLESHOOTING	5-1
--------------------------------------	-----

Distribution Statement A. Approved for public release; distribution is unlimited.

HEADQUARTERS, DEPARTMENT OF THE ARMY
28 FEBRUARY 1994

WARNINGS

DEATH or serious injury may result if personnel fail to observe the following safety precautions.

FLAMMABLE FUEL

- Fuels are toxic and flammable. Wear protective goggles and refuel only in well-ventilated area. Avoid contact with skin, eyes, and clothes and don't breathe vapors. Do not use near open flame or excessive heat. If you become dizzy, get fresh air immediately, flush with clean water and get medical aid for eyes immediately.
- BEFORE OPERATION be certain nozzle is secure to avoid spillage of fuel. Do not allow any smoking within 100 feet of the fuel servicing areas. Post NO SMOKING signs around the areas. Be certain a suitable fire extinguisher is present.
- DURING OPERATION avoid spillage of fuel as much as possible. If spillage of fuel occurs, cover the areas with dry soil to reduce its rate of vaporization. Avoid getting fuel on the body or clothing. If clothing becomes saturated with fuel, remove the clothing immediately and wash the body with hot soapy water. Do not allow smoking within 100 feet of the dispensing area. Post NO SMOKING signs around the areas. Be certain the nozzle is properly bonded to the vehicle being filled. The vehicle being filled and the dispensing pump must be grounded. Be certain a suitable fire extinguisher is present and has been properly filled. Never dispense fuel to a vehicle while its engine is operating.

SOLVENT HAZARD

Drycleaning solvent, PD 680, Type III, used to clean parts, is potentially dangerous to personnel and property. Eye protection required. Avoid repeated and prolonged skin contact by wearing rubber or nonporous gloves when handling solvents or material wet with drycleaning solvent. Wash hands immediately after exposure with soap and water and use a lanolin based skin cream to prevent skin drying. Do not use near open flame or excessive heat. Do not work with solvent in a closed room. Be sure there is good ventilation or the solvent vapors will build up in the air and become a poisonous mixture which can cause physical injury or even death.

WARNINGS - cont

COMPRESSED AIR HAZARD

Compressed air can blow dust into the eyes. Wear eye protection. Do not exceed 30 psig working pressure.

STATIC DISCHARGE

A static discharge between the vehicle and CCR Nozzle could ignite the fuel or cause an explosion of fuel vapors. Do not operate the nozzle until it has first been properly grounded to vehicle.

ARCING

Radio transmitters can cause an arc at antennas. Do Not ground nozzle to a radio antenna.

FUEL SPILLAGE ON PERSONNEL

Avoid getting fuel on your body or clothing. If clothing becomes saturated with fuel, remove clothing immediately and wash your body with hot soapy water.

FIRST AID instructions are given in FM 21-11, First Aid For Soldiers.

CHANGE

NO. 1

HEADQUARTERS
DEPARTMENT OF THE ARMY
WASHINGTON, D.C., 1 MARCH 1999

OPERATOR'S, UNIT, AND DIRECT SUPPORT
MAINTENANCE MANUAL
INCLUDING REPAIR PARTS AND SPECIAL TOOLS LIST (RPSTL)
FOR
CLOSED CIRCUIT REFUELING NOZZLE ASSEMBLY
MODEL 64017B
NSN: 4930-01-383-9467

DISTRIBUTION STATEMENT A: Approved for public release; distribution is unlimited.

TM 10-4930-248-13&P, 28 February 1994 is changed as follows:

1. Remove and insert pages as indicated below. New or changed text material is indicated by a vertical bar in the margin. An illustration change is indicated by a miniature pointing hand.

Remove pages

i and ii
1-1 through 1-5/(1-6 blank)
4-1 and 4-2
4-11 and 4-12
5-1 and 5-2
5-21/(5-22 blank)
A-1/(A-2 blank)
C-7 and C-8
(C-11 blank)/C-12
C-15 through C-19/(C-20 blank)
F-1 and F-2
J-1/(J-2 blank)
Index-1 and Index-2

insert pages

i and ii
1-1 through 1-5/(1-6 blank)
4-1 and 4-2
4-11 through 4-12.4
5-1 and 5-2
5-21 through 5-40
A-1/(A-2 blank)
C-7 and C-8
(C-11 blank) through C-12.6
C-15 through C-19/(C-20 blank)
F-1 and F-2
J-1/(J-2 blank)
Index-1 and Index-2

2. Retain this sheet in front of manual for reference purposes.

By Order of the Secretary of the Army:

DENNIS J. REIMER
General, United States Army
Chief of Staff

Official:



JOEL B. HUDSON

Administrative Assistant to the
Secretary of the Army

05761

DISTRIBUTION: To be distributed in accordance with the Initial
Distribution Number (IDN) 256126, requirements for TM
9-2320-279-10-2.

TECHNICAL MANUAL
NO: TM 10-4930-248-13&P

HEADQUARTERS
DEPARTMENT OF THE ARMY
WASHINGTON, D.C. 28 February 1994

OPERATOR'S, UNIT, AND DIRECT SUPPORT
MAINTENANCE MANUAL
INCLUDING REPAIR PARTS AND SPECIAL TOOLS LIST (RPSTL)
FOR
CLOSED CIRCUIT REFUELING NOZZLE ASSEMBLY
MODEL 64017B
NSN: 4930-01-383-9467

REPORTING ERRORS AND RECOMMENDING IMPROVEMENTS

You can help improve this publication. If you find any mistakes or if you know of a way to improve the procedures, please let us know. Submit your DA Form 2028-2 (Recommended Changes to Equipment Technical Publications), through the Internet, on the Army Electronic Product Support (AEPS) website. The Internet address is <http://aeps.ria.army.mil>. If you need a password, scroll down and click on "ACCESS REQUEST FORM". The DA Form 2028 is located in the ONLINE FORMS PROCESSING section of the AEPS. Fill out the form and click on SUBMIT. Using, this form on the AEPS will enable us to respond quicker to your comments and better manage the DA Form 2028 program. You may also mail, fax or email your letter, DA Form 2028, or DA Form 2028-2 direct to: Commander, U.S. Army Tank -automotive and Armaments Command, ATTN: AMSTA-AC-NML, Rock Island, IL 61299-7630. The email address is amsta-ac-nml@ria.army.mil. The fax number is DSN 793-0726 or Commercial (309) 782-0726.

TABLE OF CONTENTS

	PAGE
HOW TO USE THIS MANUAL	iii
CHAPTER 1. INTRODUCTION	1-1
Section I. General Information	1-1
Section II. Equipment Description	1-3
Section III. Principles of Operation	1-5
CHAPTER 2. OPERATING INSTRUCTIONS	2-1
Section I. Description and Use of Operator's Controls and Indicators	2-1
Section II. Operator Preventive Maintenance Checks and Services (PMCS)	2-3
Section III. Operation Under Usual Conditions	2-10
Section IV. Operation Under Unusual Conditions	2-13
CHAPTER 3. OPERATOR MAINTENANCE INSTRUCTIONS	3-1
Section I. Lubrication Instructions	3-1
Section II. Operator Troubleshooting	3-1
Section III. Operator Maintenance Procedures	3-4
CHAPTER 4. UNIT MAINTENANCE	4-1
Section I. Repair Parts and Special Tools List	4-1
Section II. Unit Preventive Maintenance Checks and Services (PMCS)	4-2
Section III. Unit Troubleshooting Procedures	4-3
Section IV. Unit Maintenance Procedures	4-7
Section V. Preparation for Storage or Shipment	4-12.4

TABLE OF CONTENTS - continued

	PAGE
CHAPTER 5. DIRECT SUPPORT MAINTENANCE	5-1
Section I. Direct Support Troubleshooting	5-1
Section II. Direct Support Maintenance Instructions	5-1
APPENDICES	
Appendix A. References	A-1
Appendix B. Maintenance Allocation Chart	B-1
Appendix C. Repair Parts and Special Tools List	C-1
Section I. Introduction	C-1
Section II. Repair Parts List	C-1
Group 01 Figure 1. Nozzle Assembly	C-8
Group 02 Figure 2. Special Tools	C-9
Appendix D. Components of End Item and Basic Issue Items List	D-1
Appendix E. Additional Authorization List	E-1
Appendix F. Expendable and Durable Items List	F-1
Appendix G. Lubrication Instructions	G-1
Appendix H. Illustrated List of Manufactured Items	H-1
Appendix I. Torque Limits	I-1
Appendix J. Mandatory Replacement Parts	J-1
GLOSSARY	Glossary-1
ALPHABETICAL INDEX	Index-1

HOW TO USE THIS MANUAL

Be sure to read all Warnings before using your equipment.

This manual incorporates a quick reference tab feature that allows you to quickly locate the most often referenced subjects and topics appearing in this manual. The reference tab feature is comprised of the following components:

Cover Page Index

Index boxes are located on the right-hand edge of the cover page. Each index box contains a subject title, page number, and black index tab.

Table of Contents

The Table of Contents lists all the major subjects contained in this manual. Subjects that are surrounded by a black box correspond to those that appear on the cover page index.

Page Numbers and Index Tabs

Each page of this manual is identified with a page number. Pages that contain the subjects identified on the cover page index also contain a black tab on the right edge of the page that aligns with the cover page index tab.

To use the quick reference tab feature, select the title of the subject you are trying to find from the cover page index. You can turn to the indicated page number or bend the pages back and locate the page tab that aligns with the cover index tab.

If the cover page is lost or badly worn, page numbers and index tabs can be located by referring to the Table of Contents.



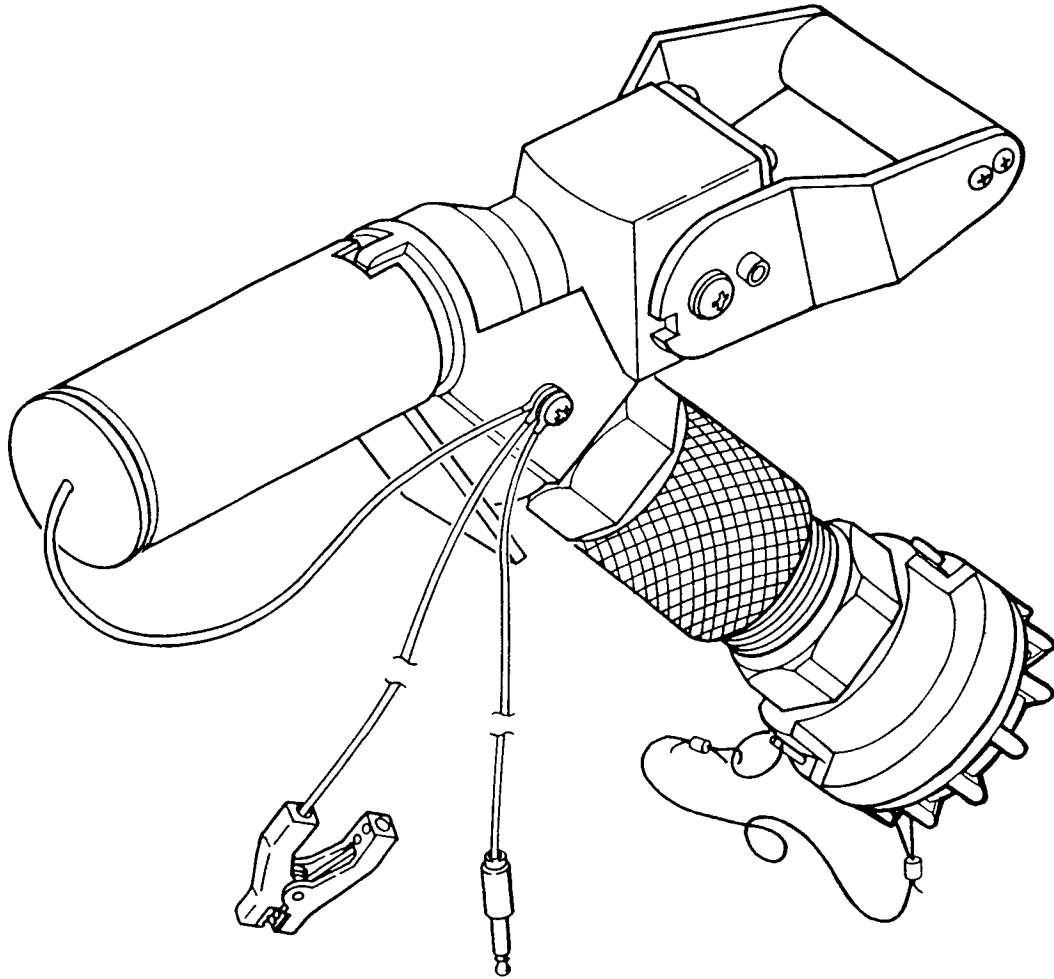

CHAPTER 1

INTRODUCTION

Section I. GENERAL INFORMATION

1-1. SCOPE.

- a. Type of Manual. Operator's, Unit, and Direct Support Maintenance Manual, including Repair Parts and Special Tools List (RPSTL).
- b. Model Number and Equipment Name. Model 64017B Nozzle Assembly, Closed-Circuit Refueling.
- c. Purpose of Equipment. The Closed Circuit Refueling Nozzle Assembly (CCR Nozzle) is a component of the HEMTT Tanker Aircraft Refueling System (HTARS) and the Advanced Aviation Forward Area Refueling System (AAFARS). The CCR Nozzle's primary purpose is to fuel/refuel aircraft and motor vehicles. Fueling of motor vehicles requires the use of a gravity fill nozzle adapter connected to the CCR Nozzle. The adapter is supplied with HTARS and AAFARS.

1-2. MAINTENANCE FORMS , RECORDS AND REPORTS.

Maintenance forms and records that you are required to use are DA Form 2402 (Exchange Tag), DA Form 5504 (Maintenance Request), and Standard Form 368 (Quality Deficiency Report). Their use and procedures for filling these forms are explained in DA PAM 738-750, The Army Maintenance Management System (TAMMS)

1-3. DESTRUCTION OF ARMY MATERIEL TO PREVENT ENEMY USE.

Refer to TM 750-244-3 for instructions for destruction of equipment to prevent enemy use.

1-4. CORROSION PREVENTION AND CONTROL (CPC).

Corrosion Prevention and Control (CPC) of Army materiel is a continuing concern. It is important that any corrosion problems with this item be reported so that the problem can be corrected and improvements made to prevent the problem in future items.

While corrosion is typically associated with rusting of metals, it can also include deterioration of other materials, such as rubber and plastic. Unusual cracking, softening, swelling or breaking of the materials may be a corrosion problem.

If a corrosion problem is identified, it can be reported using Standard Form 368, Product Quality Deficiency Report. Using key words such as "corrosion", "rust", "deterioration", or "cracking" will ensure that the information is identified as a CPC problem.

The form should be submitted to the address specified in DA PAM 738-750.

1-5. REPORTING EQUIPMENT IMPROVEMENT RECOMMENDATIONS (EIRS).

If your CCR Nozzle needs improvement, let us know. Send us an EIR. You, the user, are the only one who can tell us what you don't like about your equipment. Let us know why you don't like the design or performance. Put it on an SF 368 (Product Quality Deficiency Report). Mail it to us at Commander, U.S. Army Tank-Automotive and Armaments Command, ATTN: AMSTA-TR-E/MPA Warren, Mi. 48397-50000. We will send you a reply.

1-6. QUALITY ASSURANCE (QA) PROCEDURES.

Critical procedures or parts of procedures in this TM which require quality assurance inspections are identified by "(QA)" written after the applicable step.

1-7. NOMENCLATURE CROSS REFERENCE LIST.

Common Name

Official Nomenclature

CCR Nozzle Nozzle Assembly, Closed Circuit Refueling

1-8. LIST OF ABBREVIATIONS/ACRONYMS.

App	Appendix
CCR	Closed-Circuit Refueling
CN	Can
F	Fahrenheit
GL	Gallon
in. lb.	Inch Pounds
LB	Pounds
PN	Part Number
psig	Pounds-force per square inch, Gage
PT	Pint
TU	Tube

1-9. GLOSSARY.

Packing O-Ring Seals

Section II. EQUIPMENT DESCRIPTION

1-10. EQUIPMENT CHARACTERISTICS, CAPABILITIES AND FEATURES.

a. Characteristics.

- (1) Two-position flow control handle.
- (2) Nozzle locks onto vehicle adapter.
- (3) Indicator shows when fuel flow has stopped.

b. Capabilities and Features.

- (1) Regulates fuel delivery pressure.
- (2) Built-in fuel strainer removes contaminants from fuel.
- (3) Control handle latches in closed position.
- (4) Plug and clamp type grounding cable assemblies provided.
- (5) Automatic fuel shutoff when CCR Nozzle is disconnected from vehicle adapter.
- (6) Dust cap and plug protect CCR Nozzle from contamination when not in use.

This technical manual provides coverage of both types of CCR Nozzle Model Numbers 64017B. One type CCR Nozzle contains a diaphragm assembly and a rubber sleeve. The other type contains a piston actuator assembly and a teflon sleeve to control fuel flow.

CCR Nozzles with serial numbers through 5794 contain a diaphragm assembly.

CCR Nozzles with serial numbers 5795 and up contain a piston assembly.

NOTE

The diaphragm related parts are no longer available for repairs. A new parts kit (Part Number KD 64017-2) must be used to convert these diaphragm activated nozzles to a piston activated type. Stamp an "X" on the data plate below the model number of the CCR nozzle that has been converted to the piston type. The conversion kit contains parts that are not required for the repair of a piston activated nozzle.

1-11. LOCATION AND DESCRIPTION OF MAJOR COMPONENTS.

- a. Nozzle Housing. The nozzle housing (1) contains the poppet assembly and pressure regulator.
- b. Nozzle Collar. The nozzle collar (2) mates with the vehicle receptacle. The locking lugs are housed and actuated by the collar.
- c. Handle Assembly. The handle assembly (3) allows for manual ON/OFF control of the flow rate; either no flow or full flow.
- d. Strainer Housing. The strainer housing (4) houses the fuel strainer.
- e. Cover. A cover (5) is furnished to cover the nozzle outlet when not connected to a system for servicing.
- f. Ground Cable. A ground cable (6) is provided for grounding to the vehicle prior to connection. A ground plug is provided for inserting into the vehicle ground receptacle. A clip type connector is used where a ground plug receptacle is not available.
- g. Coupling Assembly. The coupling assembly (7) allows the nozzle assembly to be connected and disconnected from the fuel hose supply.

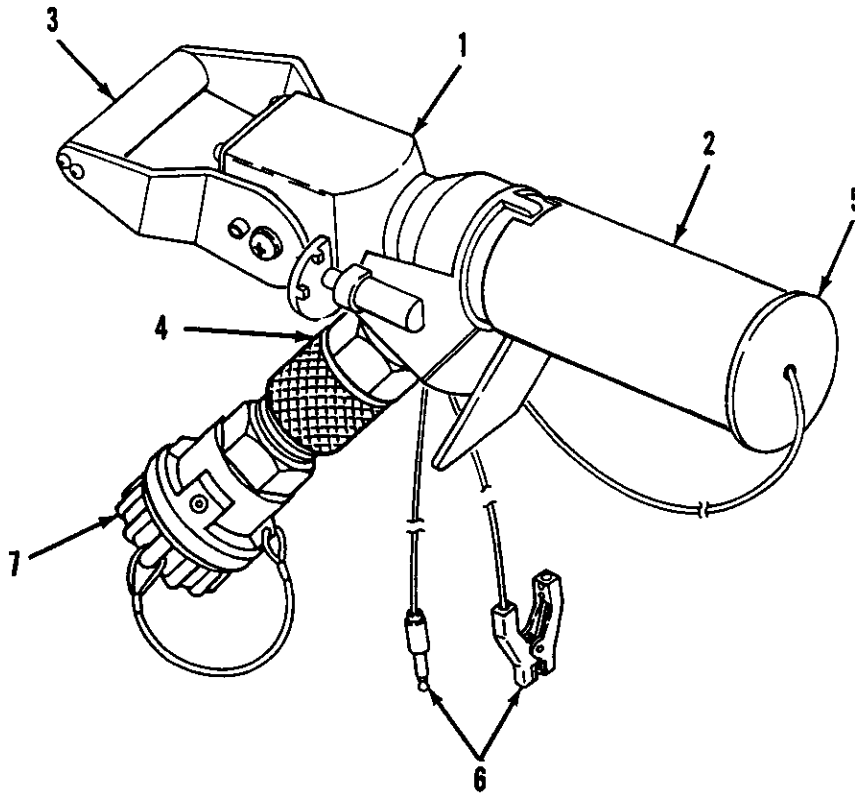

1-12. EQUIPMENT DATA.

GENERAL

Type: MIL-N-52747D(ME), Type IB Standard Services, with 2 inch coupling.

Weight: 8 lb (3.7 kg) Maximum

Maximum Dimensions: 10 inches L, 4 inches W, 9 inches H; not including Strainer Assembly and Coupling.

Nozzle Disengagement Force: 10 to 32 lb

Environmental Conditions:

- Operating Temperature Range: -25°F to + 140°F
- Operating Relative Humidity: Zero to 100%
- Sand and Dust: Exposure to desert environment.
- Storage Temperature Range: -50°F to + 150°F

Section III. PRINCIPLES OF OPERATION**1-13. SYSTEM TECHNICAL PRINCIPLES OF OPERATION.**

The CCR Nozzle delivers pressure-regulated fuel to the closed-circuit adapter, the collar moves forward, locking the nozzle in place. The vehicle adapter contains an orifice sized to provide a predetermined fuel flow rate.

In addition to regulating fuel delivery pressure, the CCR Nozzle serves as a fuel on-off valve. The valve is operated manually to either the closed or the flow (open) position. The internal poppet is then seated closed, shutting off flow.

Fuel flow is initiated by pushing forward on the handle latch, releasing the handle, then moving the handle up to the flow position. This unlocks the internal valve poppet and diaphragm/piston allowing the fuel regulator to start fuel flow.

The fuel supply pressure exerts a force on the diaphragm/piston assembly at the back of the poppet. This force is balanced by a calibrated regulator spring to maintain a valve opening which provides a nominal discharge flow from 15 to 125 psig nozzle inlet pressure.

The nozzle flow indicator, attached to the back end of the poppet, provides a visual indication that the nozzle valve is closed. This indicator is visible to the operator at the center of the end cover.

When the refueled tank is filled, the pressure difference at the nozzle outlet is reduced to zero and flow ceases. The nozzle is removed from the adapter by pulling the collar away. Before removal from the vehicle adapter, the nozzle handle should be returned to the closed position. If, in an emergency situation, the nozzle is not returned to the closed position before removal, the dry quick-disconnect action of the nozzle will close its internal valve automatically.

CHAPTER 2 OPERATING INSTRUCTIONS

PARAGRAPH	TITLE	PAGE
Section I.	Description and Use of Operator's Controls and Indicators	2-1
2.1.	Introduction	2-1
2-2.	Location and Use of Controls and Indicators	2-2
Section II.	Operator Preventive Maintenance Checks and Services (PMCS) ..	2-3
2-3.	General	2-3
2-4.	PMCS Table Columnar Headings	2-3
2-5.	Cleaning Agents.	2-5
2-6.	Leakage Definitions for Operator PMCS	2-5
2-7.	PMCS Table	2-6
Section III.	Operation Under Usual Conditions	2-10
2-8.	Assembly and Preparation for Use	2-10
2-9.	Operating Procedures	2-11
2-10.	Decals and Instruction Plates	2-13
Section IV.	Operation Under Unusual Conditions	2-13
2-11.	Unusual Environmental/Weather	2-13
2-12.	Emergency Procedures	2-15
2-13.	Nuclear, Biological, and Chemical (NBC) Decontamination Procedures .	2-15

Section I. DESCRIPTION AND USE OF OPERATOR'S CONTROLS AND INDICATORS

2-1. INTRODUCTION.

This section describes the controls and indicators you, as the operator, will be using most often. The following paragraphs will give you a brief description of each control and indicator.

2-2. LOCATION AND USE OF CONTROL AND INDICATORS.

- a. Handle (1) - Opens or closes the CCR Nozzle flow control valve. Handle is held in closed position by latch (3). Depress latch and raise handle to OPEN position to allow fuel flow. Pull handle down to CLOSED position to stop fuel flow.
- b. Flow Indicator (2) - Red indicator extends from back of CCR Nozzle when fuel flow through nozzle has stopped or handle (1) has been moved to CLOSE position.
- c. Latch (3) - Holds handle (1) in the CLOSE position. Depress latch to release handle.
- d. Quick-disconnect automatic shutoff coupler (4) - Connects to vehicle fuel servicing adapter.

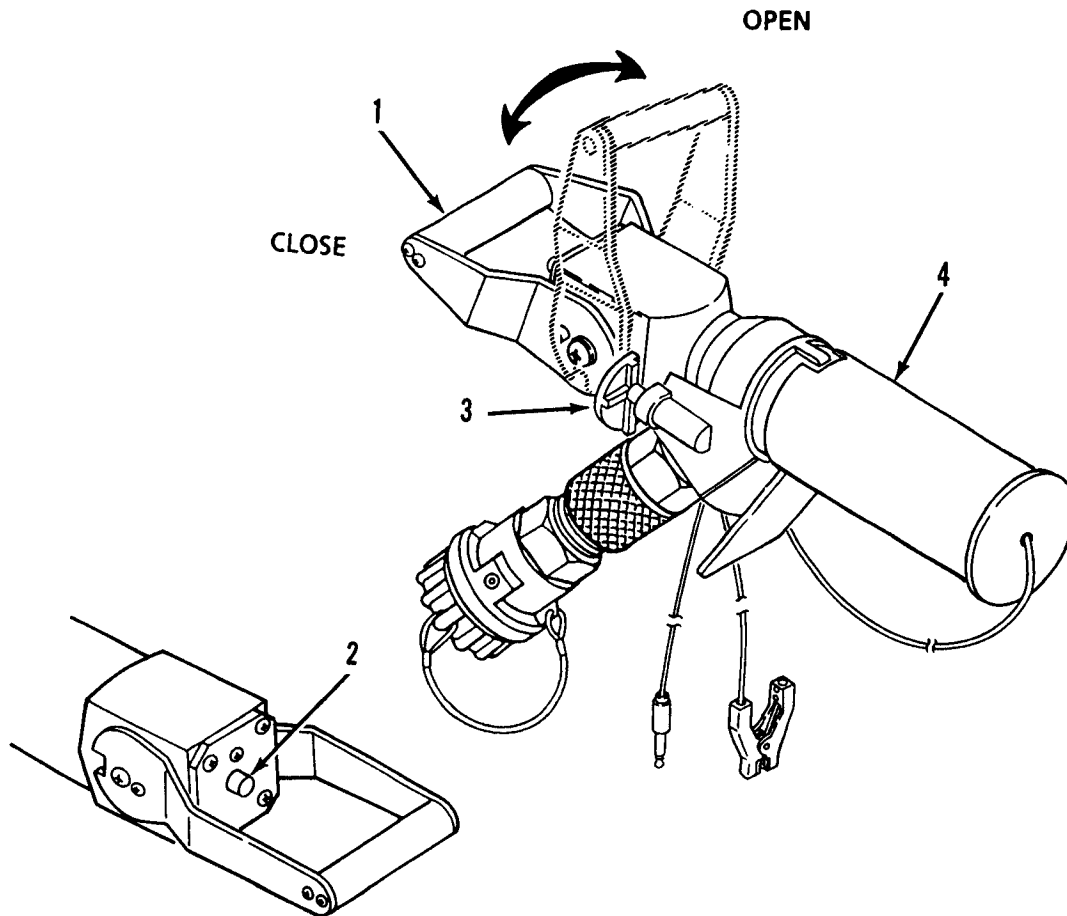

Section II. OPERATOR'S PREVENTIVE MAINTENANCE CHECKS AND SERVICES (PMCS)

2-3. GENERAL.

Preventive Maintenance Checks and Services (PMCS) means systematic caring, inspecting, and servicing of equipment to keep it in good condition and to prevent breakdowns. As the equipment operator, your mission is to:

- a. Be sure to perform your PMCS each time you operate the equipment. Always do your PMCS in the same order, so it gets to be a habit. Once you've had some practice, you'll quickly spot anything wrong.
- b. Do your **BEFORE (B)** PMCS just before you operate the equipment. Pay attention to **WARNINGS**, **CAUTIONS**, and **NOTES**.
- c. Do your **DURING (D)** PMCS while you operate the equipment. During operation means to monitor the equipment and its related components while it is actually being operated. Pay attention to **WARNINGS**, **CAUTIONS**, and **NOTES**.
- d. Do your **AFTER (A)** PMCS right after operating the equipment. Pay attention to **WARNINGS**, **CAUTIONS**, and **NOTES**.
- e. Do your **WEEKLY (W)** PMCS once a week.
- f. Do your **MONTHLY (M)** PMCS once a month.
- g. Use DA Form 2404 (Equipment Inspection and Maintenance Worksheet) to record any faults that you discover before, during, or after operation, unless you can fix them. You **DO NOT** need to record faults that you fix.
- h. Be prepared to assist organizational maintenance when they lubricate the equipment. Perform any other services when required by organizational maintenance.

2-4. PMCS TABLE COLUMNAR HEADINGS.

- a. Your Preventive Maintenance Checks and Services, Table 2-1, lists inspections and care required to keep your equipment in good operating condition. It is set up so you can make your **BEFORE (B) OPERATION** checks as you walk around the equipment. The "**ITEM**" column of Table 2-1 relates to the callouts illustrations and is a numeric listing of the sequence in which the services and inspections are performed.
- b. The "**INTERVAL**" column of Table 2-1 tells you when to do a certain check or service.
- c. The "**PROCEDURE**" column of Table 2-1 tells you how to do required checks and services. Carefully follow these instructions. If you do not have tools, or if the procedure tells you to, notify your supervisor.

2-4. PMCS TABLE COLUMNAR HEADINGS - continued.

NOTE

Terms “ready/available” and “mission capable” refer to same status: Equipment is on hand and ready to perform its combat missions. (See DA Pam 738-750).

- d. The “NOT FULLY MISSION CAPABLE IF:” column in Table 2-1 tells you when your equipment is not mission capable and why the equipment cannot be used.
- e. If the equipment does not perform as required, refer to Chapter 3, Section II, Troubleshooting.
- f. If anything looks wrong and you can't fix it, write it on your DA Form 2404. IMMEDIATELY, report it to your supervisor.
- g. When you do your PMCS, you will always need a rag or two. The following checks are common to the entire CCR Nozzle:
 - (1) **Keep It Clean.** Dirt, grease and oil collect dust which may cover up a serious problem. Clean as you work and as needed. Use dry cleaning solvent on all metal surfaces. Use soap and water when you clean rubber or plastic material.
 - (2) **Rust and Corrosion.** Check equipment for rust and corrosion. If any bare metal or corrosion exists, clean, and apply a thin coat of oil. Report it to your supervisor.
 - (3) **Bolts, Nuts, and Screws.** Check them all for obvious looseness, missing, bent, or broken condition. You can't try them all with a tool, but look for chipped paint, bare metal, or rust around bolt heads. If you find a bolt, nut or screw you think is loose, tighten it or report it to your supervisor.
 - (4) **Welds.** Look for loose or chipped paint, rust, or gaps where parts are welded together. If you find a bad weld, report it to your supervisor.
 - (5) **Electric Wires and Connectors.** Look for cracked, frayed, or broken insulation, bare wires, and loose or broken connectors. Tighten loose connectors. Report any damaged wires to your supervisor.
 - (6) **Hoses and Fluid Lines.** Look for wear, damage, and leaks, and make sure clamps and fittings are tight. Wet spots show leaks, but a stain around a fitting or connector can also mean a leak. If a leak comes from a loose fitting or connector, tighten it. If something is broken or worn out, report it to your supervisor.
- h. When you check for “operating condition”, you look at the component to see if it's serviceable.

2-5. CLEANING AGENTS.**WARNINGS**

- DO NOT use diesel fuel, gasoline, or benzene (benzol) for cleaning.
- DO NOT SMOKE when using cleaning solvent. NEVER USE IT NEAR AN OPEN FLAME. Be sure there is a fire extinguisher nearby and use cleaning solvent only in well-ventilated places. Flash point of solvent is 138°F (60°C).
- USE CAUTION when using cleaning solvents. Cleaning solvents evaporate quickly and can irritate exposed skin if solvents contact skin. In cold weather, contact of exposed skin with cleaning solvents can cause frostbite.

Cleaning Rust or Grease. When removing grease buildup, use a cleaning solvent. Apply a thin coat of light oil to all bare metal surfaces to prevent corrosion.

2-6. LEAKAGE CRITERIA.**WARNING**

- To prevent injury to personnel and damage to equipment, be certain all system components are securely connected before operation to avoid fuel spills.
- Fuel vapors are extremely flammable. Do not allow smoking within 100 feet of the fuel servicing areas. Be certain a suitable and properly charged fire extinguisher is available at all times.

No fuel leaks are permissible when operating the CCR nozzle. Immediately report all leaks to your supervisor.

2-7. PMCS TABLE.

Table 2-1 contains a tabulated listing of preventive maintenance checks and services which must be performed by the operator.

Table 2-1. Operator Preventive Maintenance Checks and Services (Model 64017B).

NOTE: Within designated interval, these checks are to be performed in the order listed.

ITEM NO.	INTERVAL	LOCATION	PROCEDURE	NOT FULLY MISSION CAPABLE IF:
		ITEM TO BE INSPECTED		
		CLOSED-CIRCUIT REFUELING NOZZLE		
1	Before	Locking Lugs and Stayback Lugs	Remove dust cover. Inspect for missing or damaged lugs. There should be three stayback lugs and nine locking lugs.	Lugs missing or damaged.
2	Before	Nozzle Housing	Inspect for leaks.	Any leak found.
3	Before	Handle	Inspect handle action to see that it operates smoothly.	Fails to operate smoothly.
4	Before	Cable Assembly	Inspect cable for loose connection, frayed or damaged cables, bent or damaged plug or clip.	Damaged or frayed cables. Bent or damaged plug or clip.
5	Before	Cap Assembly	Inspect cap assembly cap for cracks, burrs or damage. Inspect cable for breaks, frays and security.	
6	Before	Coupling Assembly	Inspect coupling for leaks.	Any leak found.

Table 2-1. Operator Preventive Maintenance Checks and Services (Model 64017B) - continued.

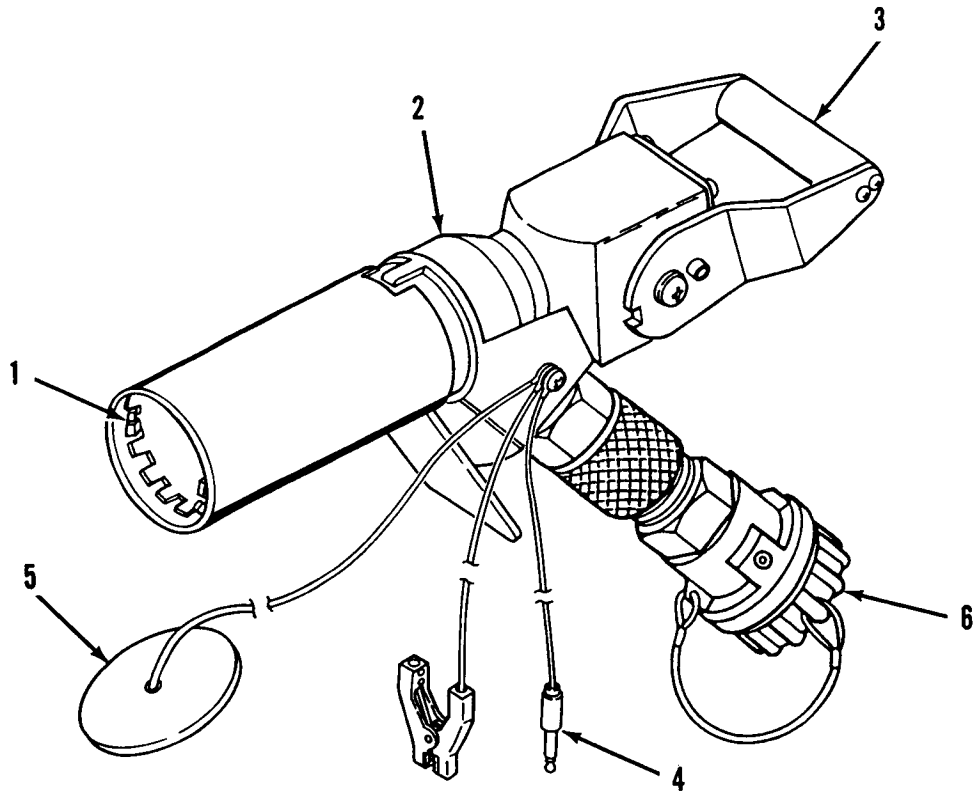
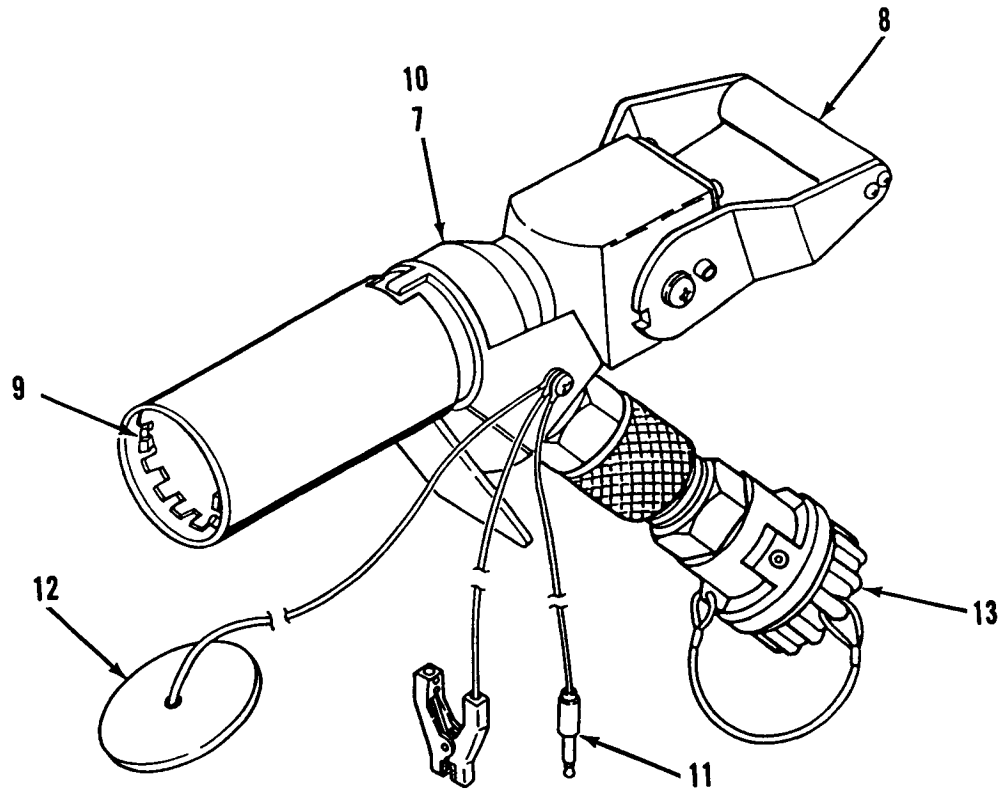

Table 2-1. Operator Preventive Maintenance Checks and Services (Model 64017B) - continued.

ITEM NO.	INTERVAL	LOCATION	PROCEDURE	NOT FULLY MISSION CAPABLE IF:
		ITEM TO CHECK/SERVICE		
		CLOSED-CIRCUIT REFUELING NOZZLE		
7	During	Nozzle Housing	Inspect for leaks.	Any leak found.
8	During	Handle	Inspect handle action to see that it operates smoothly.	Fails to operate smoothly.
9	After	Locking lugs and stayback lugs	Inspect for missing or damaged lugs. There should be three stayback lugs and nine locking lugs.	Lugs missing or damaged.
10	After	Nozzle Housing	Inspect for leaks.	Any leak found.
11	After	Cable Assembly	Inspect cable for loose connection, frayed or damaged cables, bent or damaged plug or clip.	Damaged or frayed cables. Bent or damaged plug or clip.
12	After	Cap Assembly	Inspect cap assembly cap for cracks, burrs or damage. Inspect cable for breaks, frays and security.	Cap cracked or cable broken .
13	After	Coupling Assembly	Inspect coupling for leaks.	Any leak found.

Table 2-1. Operator Preventive Maintenance Checks and Services (Model 64017B) - continued.



Section III. OPERATION UNDER USUAL CONDITIONS.

2-8. ASSEMBLY AND PREPARATION FOR USE.

Connect CCR Nozzle to Fuel Supply.

- (1) Set handle (1) on CCR Nozzle (2) to CLOSE (back) position.
- (2) Remove dust cover (3) from inlet coupling (4).
- (3) Remove the dust cover (5) from coupling (6) on fuel hose (7).
- (4) Connect inlet coupling (4) on CCR Nozzle (2) to coupling (6) on fuel hose (7).
- (5) To prevent component contamination during disassembly, connect dust cover (3) to dust cover (5).

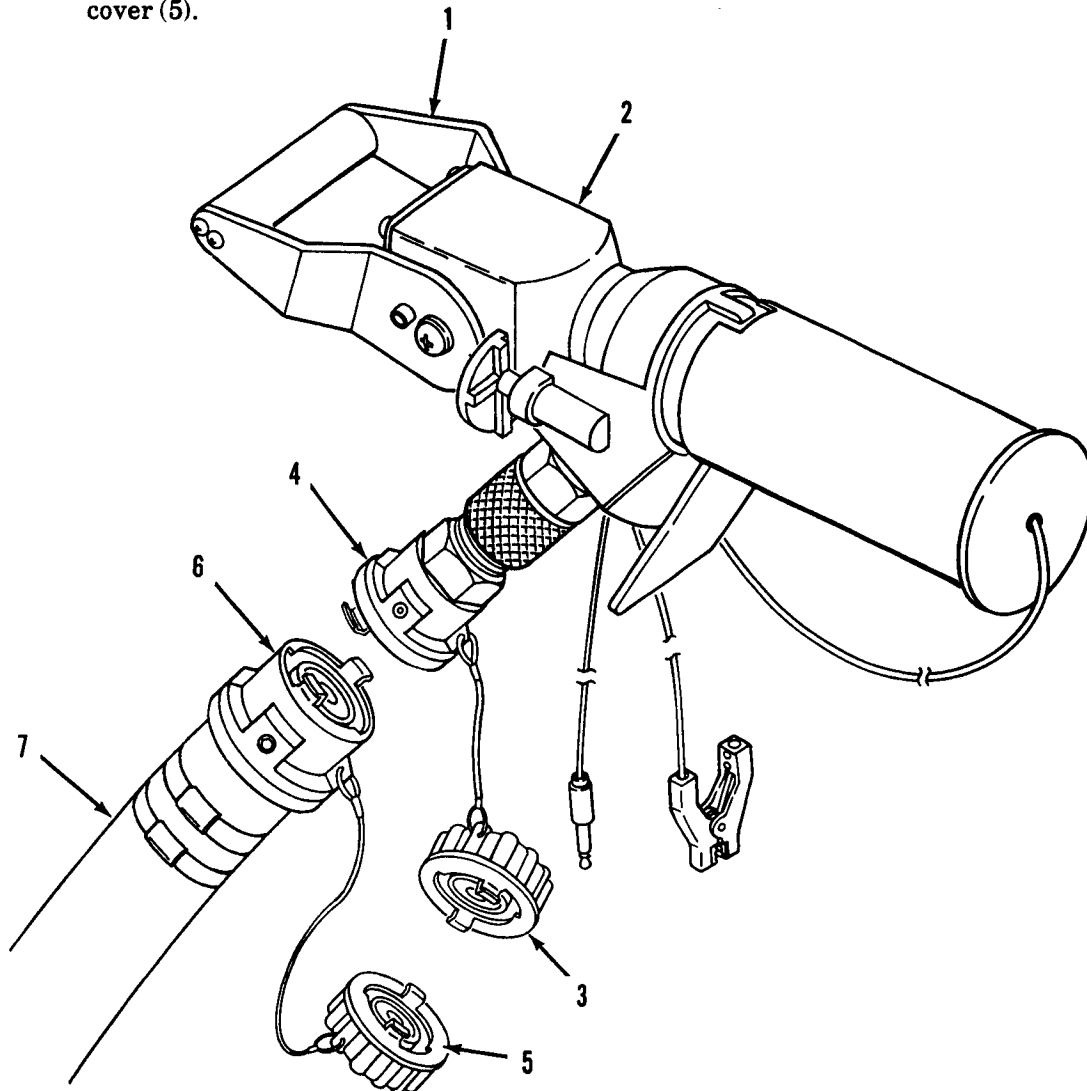

2-9. OPERATING PROCEDURES.

Operating the CCR Nozzle.

- (1) Pull back collar (1) and remove dust cap (2) from end of CCR Nozzle (6).

WARNINGS

- Do not operate the CCR Nozzle until it has first been properly grounded to the vehicle. Additional information on grounding may be obtained from TM 10-68, Aircraft Refueling.
 - A static discharge between the vehicle and CCR Nozzle could ignite the fuel or cause an explosion of fuel vapor.
 - Do not ground nozzle to a radio antenna. Radio transmitters can cause an arc at antennas.
- (2) Connect ground plug (3) to vehicle grounding jack (4) or attach nozzle grounding clamp (5) to unpainted metal surface on the vehicle, as required.
- (3) Position discharge end of CCR Nozzle (6) on vehicle fuel servicing adapter (7). Push CCR Nozzle onto servicing adapter until nozzle has seated. A positive connection is indicated by the collar (1) moving forward with an audible click.
- (4) Push latch (8), located on the right side of the CCR Nozzle (6), forward to release handle (9). Move handle to the OPEN (up) position to dispense fuel.

NOTE

When fuel flow through the CCR Nozzle has stopped, the red flow indicator will extend from the back of the CCR Nozzle body.

- (5) When fueling operation is complete, move handle (9) to the CLOSE (down) position. Make sure red flow indicator (10) has extended.
- (6) Pull collar (1) away from vehicle fuel servicing adapter (7) and disconnect CCR Nozzle (6) from vehicle.
- (7) Disconnect ground plug (3) from vehicle grounding jack (4) or detach grounding clamp (5), as required.
- (8) Install dust cap (2) on discharge end of CCR Nozzle (6).

2-9. OPERATING PROCEDURES - continued.

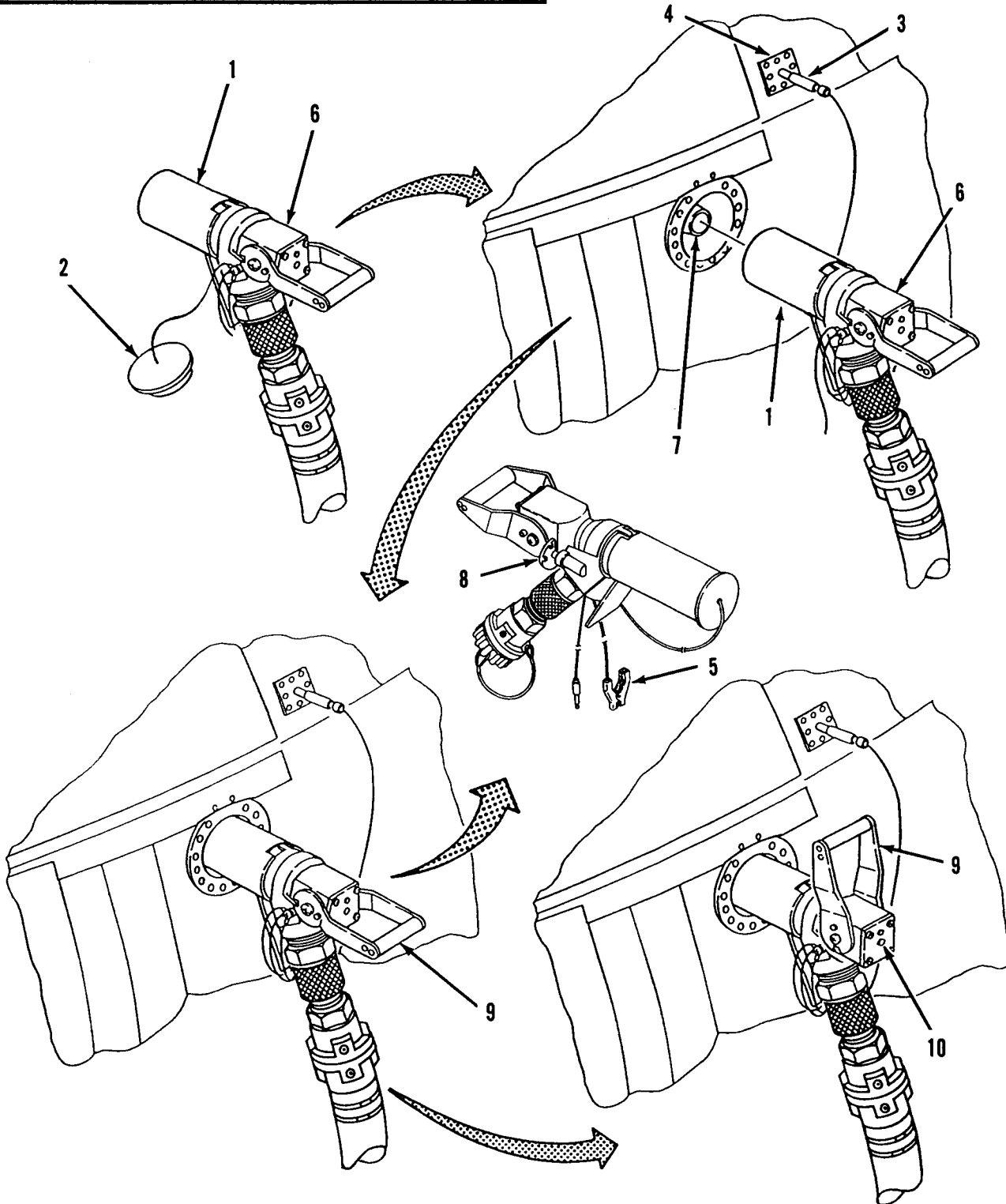

2-10. DECALS AND INSTRUCTION PLATES.

CCR NOZZLE

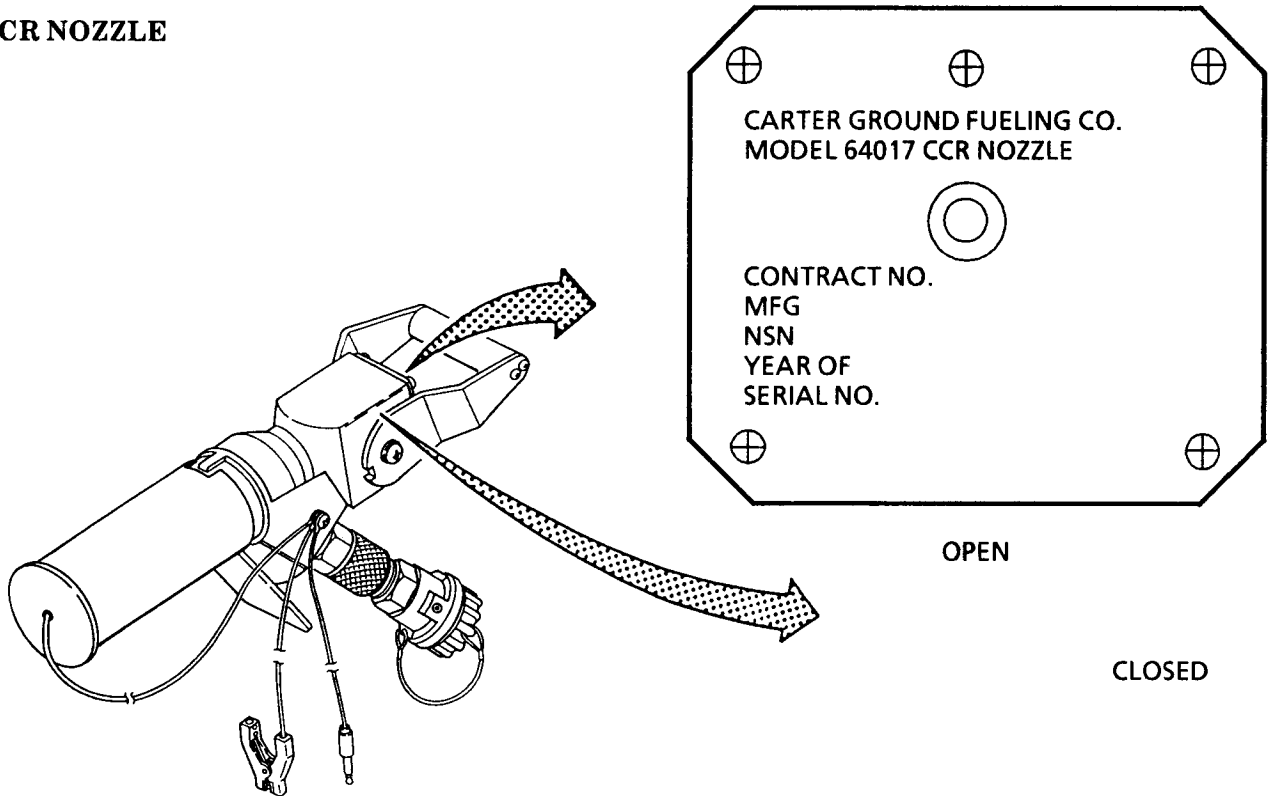

Section IV. OPERATION UNDER UNUSUAL CONDITIONS.

2-11. UNUSUAL ENVIRONMENTAL / WEATHER.

- a. Operation In Extreme Cold Conditions. Observe the following precautions when operating the CCR Nozzle in extreme cold conditions.

WARNING

Do not touch cold metal parts with bare hands when operating under extreme cold conditions. Frostbite can cause permanent injury.

- (1) Always wear arctic mittens when handling nozzle and other equipment.
- (2) Be careful when handling nozzle and hose assembly to avoid cracking hose.

2-11. UNUSUAL ENVIRONMENTAL / WEATHER - continued .

CAUTION

Accumulated ice and snow can damage nozzle assembly.

- (3) Remove snow, sleet, or ice from nozzle before refueling.
- (4) Always keep cap on the CCR Nozzle and adapter when not in use.
- (5) Perform operating procedure according to paragraph 2-7.

b. Operating the CCR Nozzle and Adapter in Strong Winds and Sandy or Dusty Conditions.

- (1) Strong Winds.
 - (a) Should not affect the performance or handling of the nozzle.
 - (b) Perform operating procedures according to paragraph 2-7.
- (2) Sandy or Dusty Conditions.
 - (a) Remove any sand or dust from the nozzle before installing to either hose or adapter.
 - (b) Keep the protective cap installed when not in use.
- (3) Perform operating procedure according to paragraph 2-7.

c. Operation in Extreme Heat Conditions.

- (1) Keep the CCR Nozzle under shade between operations.
- (2) If shade is not available, erect a tent or tarpaulin.
- (3) Perform operating procedure according to paragraph 2-7.

2-12. EMERGENCY PROCEDURES.

- a. Leakage. If nozzle leakage occurs, remove nozzle from fuel system.

CAUTION

Avoid getting fuel on the body or clothing. If clothing becomes saturated with fuel, remove clothing immediately and wash your body with hot soapy water.

NOTE

Additional information on environmental cleanup may be obtained from TM 10-68, Aircraft Refueling.

- b. Spillage. If spillage of fuel occurs, cover spill areas with dry soil to reduce vaporization rate.

2-13. NUCLEAR, BIOLOGICAL, AND CHEMICAL (NBC) DECONTAMINATION PROCEDURES.

NOTE

Detailed decontamination procedures can be found in FM 3-3, FM 3-4, and FM 3-5.

- a. General. The following emergency procedures can be followed until field NBC Decontamination Facilities are available. Assigned operators will assist the supporting NBC unit.
- b. Procedure. If NBC attack is known or suspected, mask at once and perform the following:
- (1) Stop dispensing of fuel.
 - (2) Do not disconnect the CCR Nozzle .
 - (3) Have decontamination done on the equipment before resuming operation.



CHAPTER 3
OPERATOR MAINTENANCE INSTRUCTIONS

PARAGRAPH	TITLE	PAGE
Section I.	Lubrication Instructions	3-1
Section II.	Operator Troubleshooting	3-1
3-1.	Introduction	3-1
3-2.	Malfunction Index	3-1
3-3.	Operator Troubleshooting	3-2
Section III.	Operator Maintenance Procedures	3-4

Section I. LUBRICATING INSTRUCTIONS

No lubrication of the CCR Nozzle is required.

Section II. OPERATOR TROUBLESHOOTING

3-1. INTRODUCTION.

The Malfunction Index, lists the common malfunctions which you may find during operation or maintenance of the CCR Nozzle or its components. You should perform test/inspections and corrective actions in the order listed. This manual cannot list all malfunctions that may occur nor all test or inspections and corrective actions. If a malfunction is not listed or is not corrected by listed corrective actions, notify your supervisor.

3-2. MALFUNCTION INDEX.

For quick access to troubleshooting procedures, refer to Table 3-1.

Table 3-1. Malfunction Index.

MALFUNCTION	PAGE
1. Leakage at Discharge End of Nozzle During Refueling	3-2
2. Leakage Between Nozzle Inlet Coupling and Hose Coupling	3-3

3-3. OPERATOR TROUBLESHOOTING.

Troubleshooting procedures for these malfunctions are given in Table 3-2. Notify Unit Maintenance for other malfunctions observed.

Table 3-2.Operator Troubleshooting Table.

MALFUNCTION 1. Leakage At Discharge End of Nozzle During Refueling.

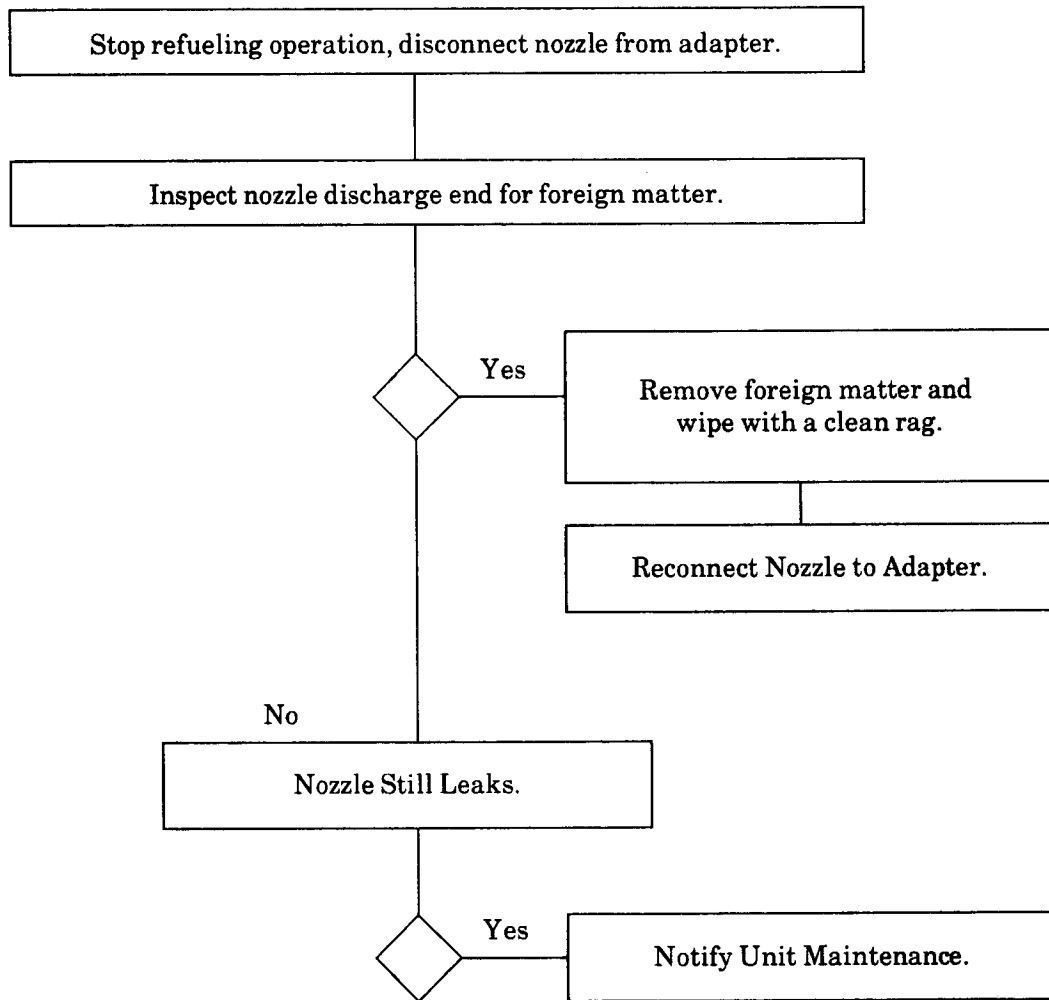
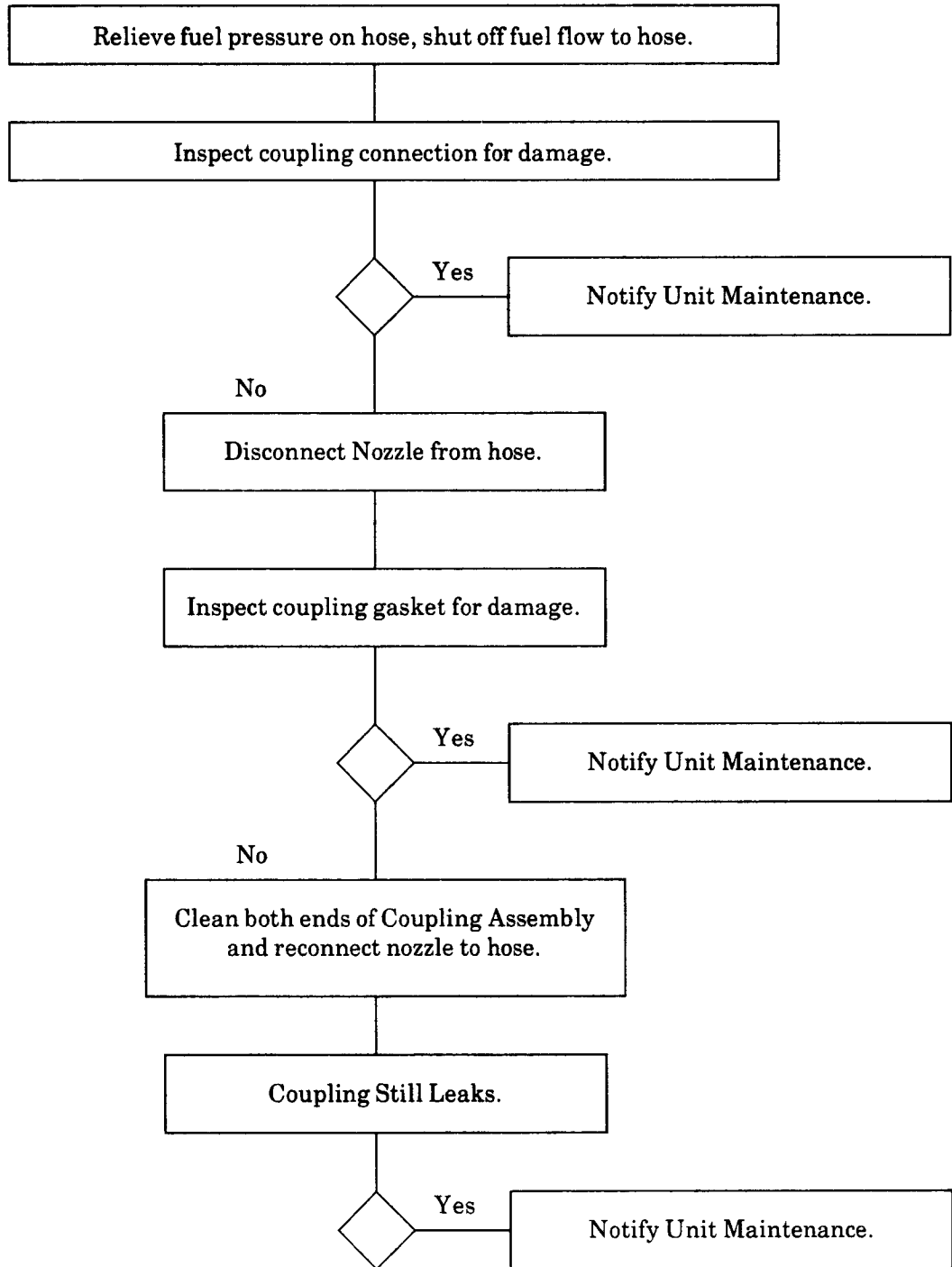

Table 3-2. Operator Troubleshooting Table - continued.

MALFUNCTION 2. Leakage Between Nozzle Inlet Coupling and Hose Coupling.



Section III. OPERATOR MAINTENANCE PROCEDURES

There are no operator maintenance procedures for the CCR Nozzle.

CHAPTER 4

UNIT MAINTENANCE INSTRUCTIONS

PARAGRAPH	TITLE	PAGE
Section I.	Repair Parts and Special Tools List	4-1
4-1.	Common Tools and Equipment	4-1
4-2.	Special Tools, TMDE and Support Equipment	4-2
4-3.	Repair Parts	4-2
Section II.	Unit Preventive Maintenance Checks and Services (PMCS)	4-2
4-4.	General	4-2
Section III.	Unit Troubleshooting Procedures	4-3
4-5.	Introduction	4-3
4-6.	Troubleshooting	4-3
Section IV.	Unit Maintenance Procedures	4-7
4-7.	General	4-7
4-8.	Personal Safety	4-7
4-9.	Proper Equipment	4-7
4-10.	CCR Nozzle Assembly Repair	4-8
4-10A.	Replace Unisex Coupling	4-12
4-10B.	Repair Unisex Coupling	4-12.2
Section V.	Preparation for Storage and Shipment	4-12.4
4-11.	Security Procedures	4-12.4
4-12.	Preparation for Movement	4-12.4
4-13.	Administrative Storage	4-13

Section I. REPAIR PARTS AND SPECIAL TOOLS LIST

4-1. COMMON TOOLS AND EQUIPMENT.

For authorized and common tools and equipment refer to the Modified Table of Organization and Equipment (MOTE) applicable to your unit.

4-2. SPECIAL TOOLS, TMDE, AND SUPPORT EQUIPMENT.

Special tools, TMDE, and support equipment are listed in the Maintenance Allocation Chart, Appendix B, and the Repair Parts and Special Tools List (RPSTL), Appendix C of this TM.

4-3. REPAIR PARTS.

Repair parts are listed and illustrated in Appendix C of this manual.

Section II. UNIT PREVENTIVE MAINTENANCE CHECKS AND SERVICES

4-4. GENERAL.

To ensure that the CCR Nozzle is ready for use at all times, it must be inspected systematically so that defects may be discovered and corrected before they result in serious damage or equipment failure. The necessary preventive maintenance checks and services to be performed are listed and described in Table 4-1. Defects discovered during operation of the unit should be corrected as soon as possible. All deficiencies and shortcomings will be recorded, together with the corrective actions taken, on DA Form 2404 (Equipment Inspection and Maintenance Worksheet) at the earliest possible opportunity.

Table 4-1. Unit Preventive Maintenance Checks and Services (Model 64017B).

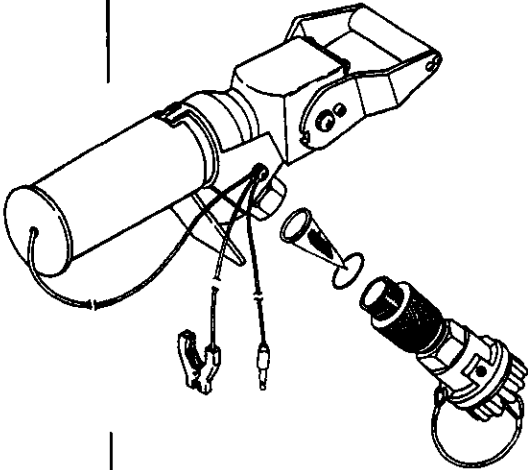
Item No.	Item to be Inspected	Interval	Procedures: Check for and have Repaired as Necessary	For Readiness Reporting Equipment is Not Ready/Available if:
1	Strainer	Every 2 weeks	<p>Check for foreign matter and holes. Clean and/or replace as required (para. 4-10).</p> 	Holes in strainer.

Section III. UNIT TROUBLESHOOTING PROCEDURES

4-5. INTRODUCTION.

This section provides troubleshooting information for the CCR Nozzle at the unit level of maintenance. It consists of the malfunction index, table 4-1, listing the most common malfunctions, and troubleshooting table, Table 4-2. The troubleshooting table is presented as flow diagrams for each malfunction listed in the malfunction index. Each diagram provides the procedure and corrective actions to return the CCR Nozzle to operational readiness.

4-6. TROUBLESHOOTING.

The troubleshooting table lists the common malfunctions which can occur in operation of the CCR Nozzle. The tests, inspections and corrective actions should be performed in the order given.

Table 4-1. Malfunction index.

MALFUNCTION	PAGE
1. Leakage Between Strainer Body and Strainer Housing,	4-4
2. Leakage Between Nozzle Inlet Coupling and Hose Coupling	4-5
3. Inadequate Fuel Flow From CCR Nozzle	4-6

Table 4-2. Unit Troubleshooting Table.

MALFUNCTION 1. Leakage Between Strainer Body and Strainer Housing

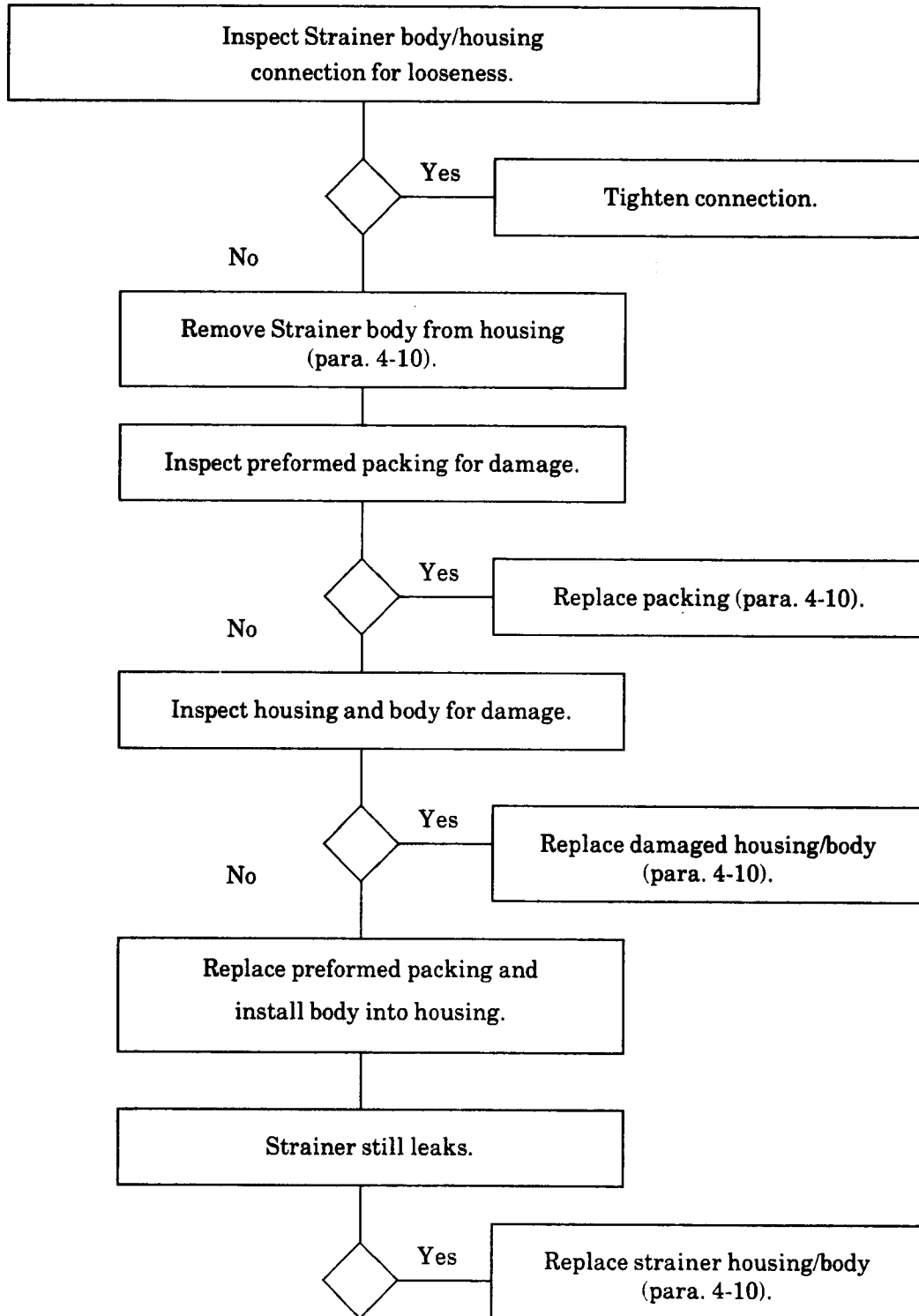

Table 4-2. Unit Troubleshooting Table - continued.

MALFUNCTION 2. Leakage Between Nozzle Inlet Coupling and Hose Coupling.

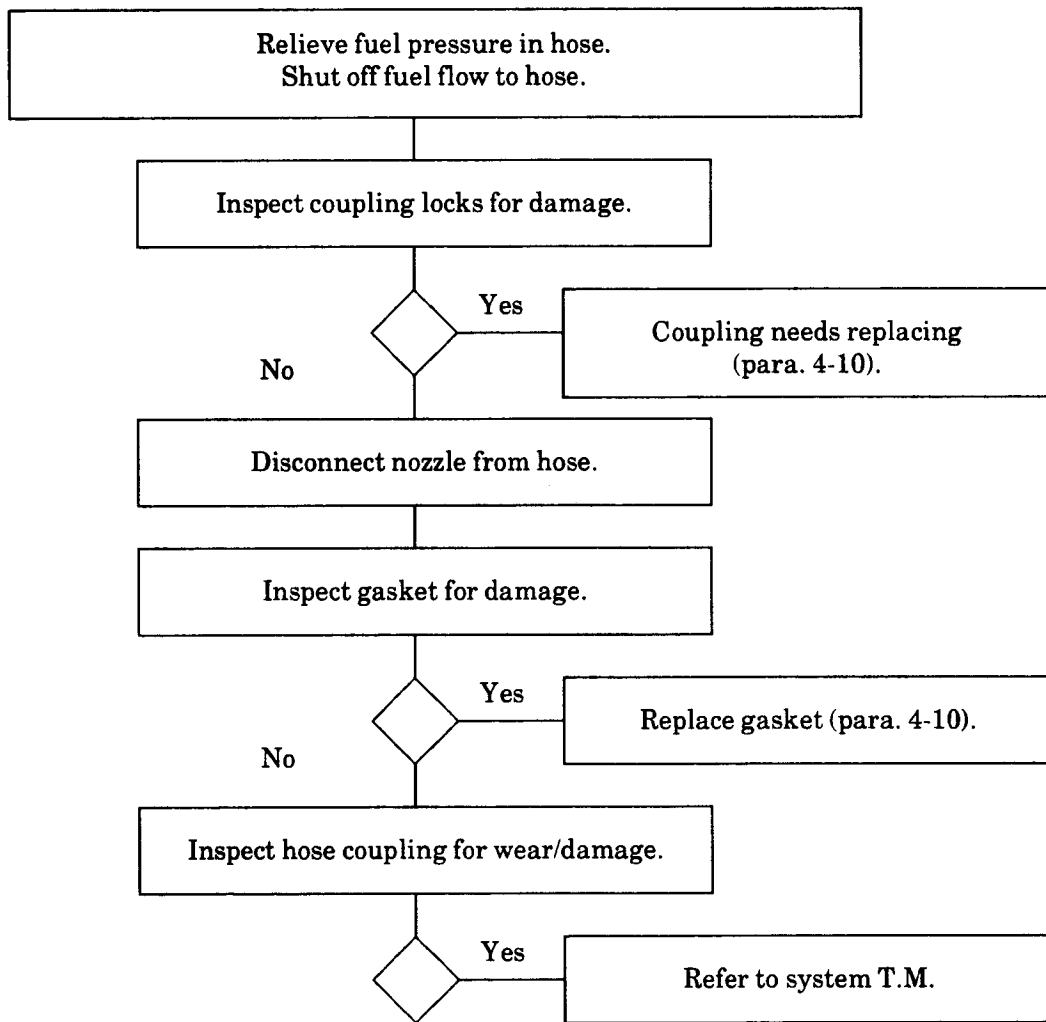
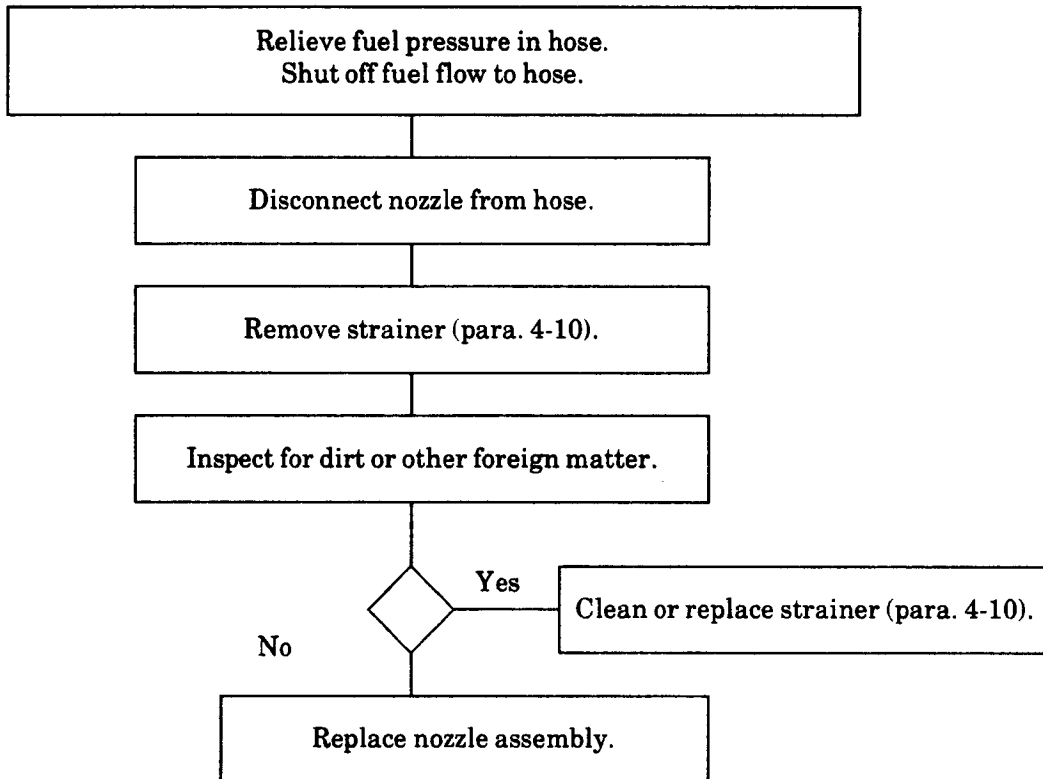

Table 4-2. Unit Troubleshooting Table - continued.

MALFUNCTION 3. Inadequate Fuel Flow From CCR Nozzle.



Section IV. UNIT MAINTENANCE PROCEDURES

4-7. GENERAL.

This section contains instructions for performing unit level maintenance on the CCR Nozzle.

4-8. PERSONNEL SAFETY.

Personnel must remove all items of jewelry (rings, bracelets, watches, necklaces, etc.) and loose clothing before working on equipment. Jewelry and loose fitting clothing can get caught in moving equipment and result in injury to personnel.

When performing maintenance of the CCR Nozzle, keep in mind the purpose of the equipment is to distribute fuel. Cleaning fluids, lubricants, preservatives, paint or other chemicals must not be allowed to contaminate the fuel.

Operate the equipment after performing maintenance to ensure repairs have been performed correctly and equipment can be returned to service.

4-9. PROPER EQUIPMENT.

Obtain proper equipment before starting maintenance. This includes hand tools and/or special tools, receptacles for storing small parts and expendable materials required by the maintenance task.

4-10. CCR NOZZLE ASSEMBLY REPAIR.

This task consists of: a. Disassembly b. Repair c. Assembly

INITIAL SET-UP:

Tools:

Tool kit, General Mechanics (Item 1, Appendix B)
Vise (Item 2, Appendix B)

Equipment Condition:

CCR Nozzle removed from fuel system.
(Reference Applicable System TM)

General Safety Requirements:

WARNINGS

- Fuels are toxic and flammable. Do not get on person or clothing. Do not use near open flame. Area should be well-ventilated.
- Using drycleaning solvents incorrectly can cause injury or even death.
- Fuel is flammable. Do not smoke.

Materials/Parts Required:

Solvent (Item 1, Appendix F)
Wiping Rag (Item 2, Appendix F)
Silicone Compound (Item 3, Appendix F)
Sealing Compound (Item 4, Appendix F)
Packing, Preformed (Item 1, Appendix J)
Gasket, Coupling (2) (Item 8, Appendix J)

a. Disassembly.

- (1) Pull the nozzle collar (1) back to release the cap (2) from the discharge end of the nozzle. Remove the cap (2).
- (2) Remove screw (3) holding the ground cable assembly (4) and cap assembly cable (2) to the nozzle housing (5).
- (3) Remove strainer body (6) and attached coupling assembly (10) from strainer housing (7).
- (4) Remove strainer (8) and preformed packing (9) from strainer housing (7). Discard packing.
- (5) Place strainer body (6) into a soft face vise.
- (6) Unscrew coupling assembly (10) from strainer body (6).
- (7) Remove dust cover (11) from coupling half (13).
- (8) Remove gasket (12) from coupling half (13).
- (9) Remove gasket (14) from dust cover (11).

4-10. CCR NOZZLE ASSEMBLY REPAIR - continued.

a. Disassembly - continued.

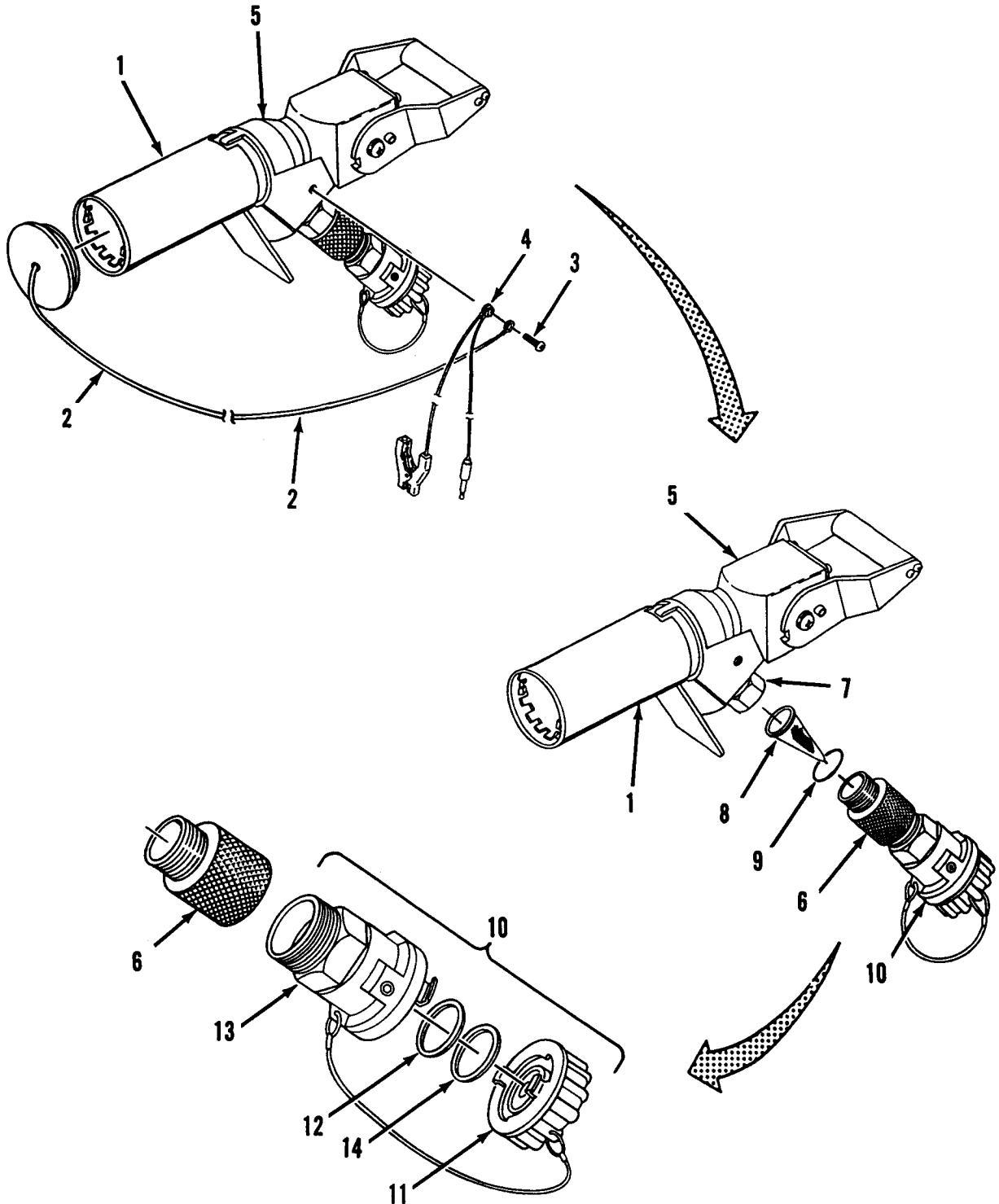

4-10. CCR NOZZLE ASSEMBLY REPAIR - continued.

WARNING

Drycleaning solvent, P-D-680 Type III, used to clean parts is potentially dangerous to personnel and property. Use in a well-ventilated area as the fumes are dangerous if inhaled. Avoid repeated and prolonged skin contact. Do not use near open flame or excessive heat. Flash point of solvent is 138°F.

b. **Repair.**

- (1) Clean parts with drycleaning solvent. Dry with clean wiping rag.
- (2) Inspect all parts for damage. Look for damaged threads, worn, scored, or deformed parts, cracks or corrosion.
- (3) Replace damaged or defective components.

c. **Assembly.**

- (1) Install gasket (14) in dust cover (11).
- (2) Install gasket (12) in coupling half (13).
- (3) Install dust cover (11) on coupling half (13).
- (4) Coat threads of coupling half (13) with sealing compound. Wipe off excess compound with clean, dry wiping rag.
- (4) Clamp strainer body (6) in a soft face vise and screw coupling half (13) into strainer body (6). Remove from vise.
- (5) Position strainer (8) in strainer housing (7).
- (6) Coat preformed packing (9) with silicone compound. Install packing over strainer and press into groove at end of strainer housing (7).
- (7) Screw strainer body (6) onto strainer housing (7) until hand tight.

NOTE

The two grounding cable lugs should be closest to the housing.

- (8) Install ground cable assembly (3) and cap assembly (2) on the housing (5) with screw (2).
- (9) Push cap (2) onto collar (1).

4-10. CCR NOZZLE ASSEMBLY REPAIR - continued.

c. Assembly - continued.

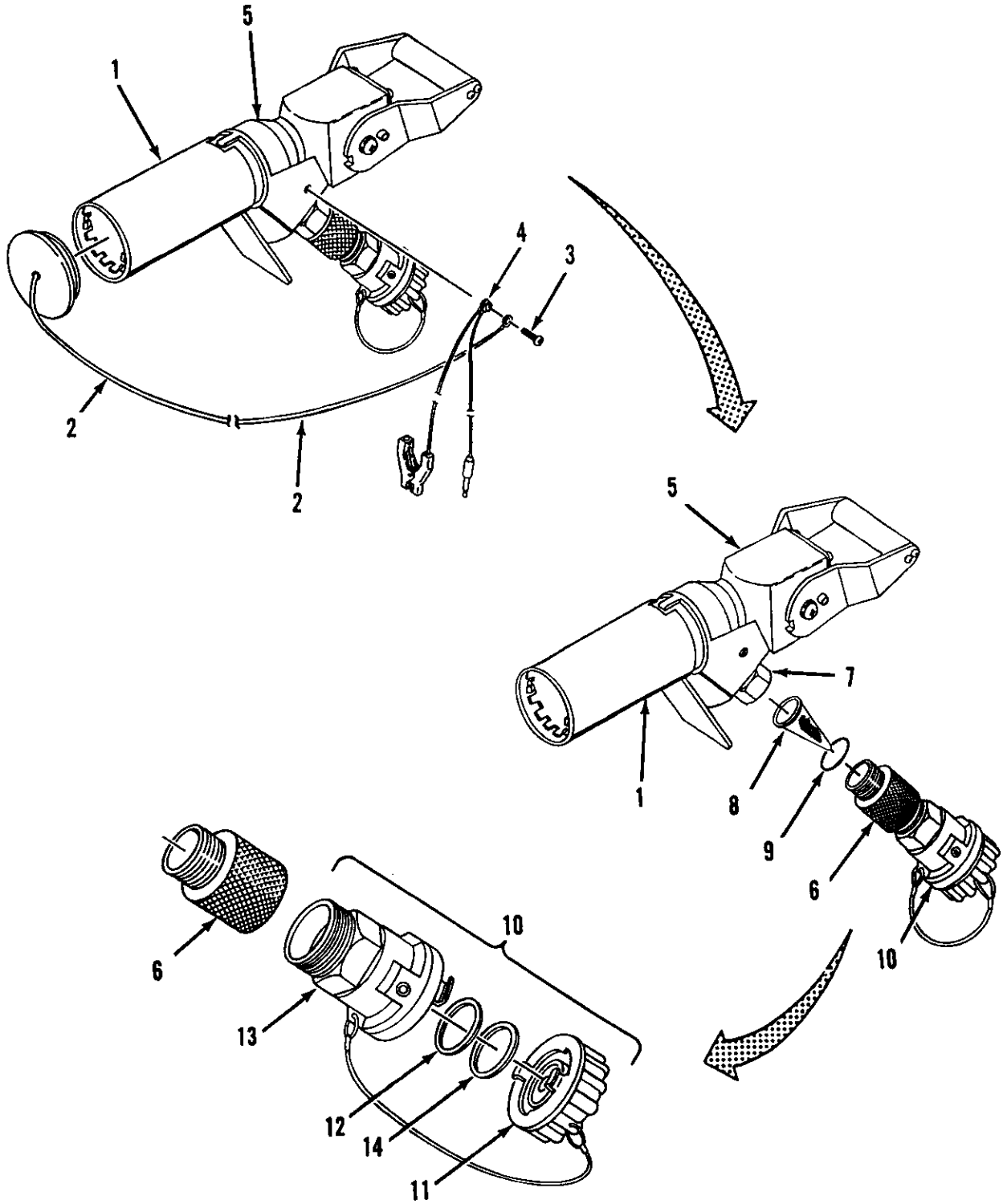

4-10A. REPLACE UNISEX COUPLING.

This task consists of: a. Removal b. Installation

INITIAL SET-UP:

Tools:

Tool Kit, General Mechanics
(Item 1, Appendix B)

Materials/Parts Required:

Packing, Preformed (Item 15, Appendix J)
Packing, Preformed (Item 16, Appendix J)
Petrolatum (Item 6, Appendix F)
Wiping Rag (Item 2, Appendix F)

General Safety Requirements:

WARNING

- Fuels are toxic and flammable. Do not get on person or clothing. Do not use near open flame. Area should be well ventilated.
- Fuel is flammable. Do not smoke.

Equipment Condition:

CCR Nozzle removed from fuel system
(Reference Applicable System TM)

a. Removal.

WARNING

Rubber gloves should be worn when handling fueling system components due to the toxic effects of some fuel additives.

- (1) Remove ball retaining screw (1) and preformed packing (2). Discard preformed packing (2).
- (2) Position a wiping rag under the coupling (3) with screw hole oriented toward wiping rag. Push in and rotate unisex coupling (3) back and forth until all 41 balls (4) have collected in the wiping rag.
- (3) Pull unisex coupling (3) from inlet (5).
- (4) Remove and discard preformed packing (6) from inlet (5).
- (5) Remove and retain spring (7) from unisex coupling.

b. Installation.

NOTE

When inserting balls in unisex coupling ball race, use caution to avoid dropping loose balls. Work over a wiping rag.

- (1) Lightly lubricate inlet preformed packing (6) with petrolatum and install in second (square) groove of inlet (5).
- (2) Place spring (7) in unisex coupling.

4-10A. REPLACE UNISEX COUPLING - continued.

- (3) Slide the unisex coupling (3) onto the inlet (5). Hold unit over a wiping rag with screw hole facing up and adjust position until ball race (rounded groove) is centered under screw hole. Install balls (4) one at a time, rotating unisex coupling back and forth until all 41 balls (4) have been inserted.
- (4) Install ball retaining screw (1) and preformed packing (2) in unisex coupling (3). Tighten retaining screw.

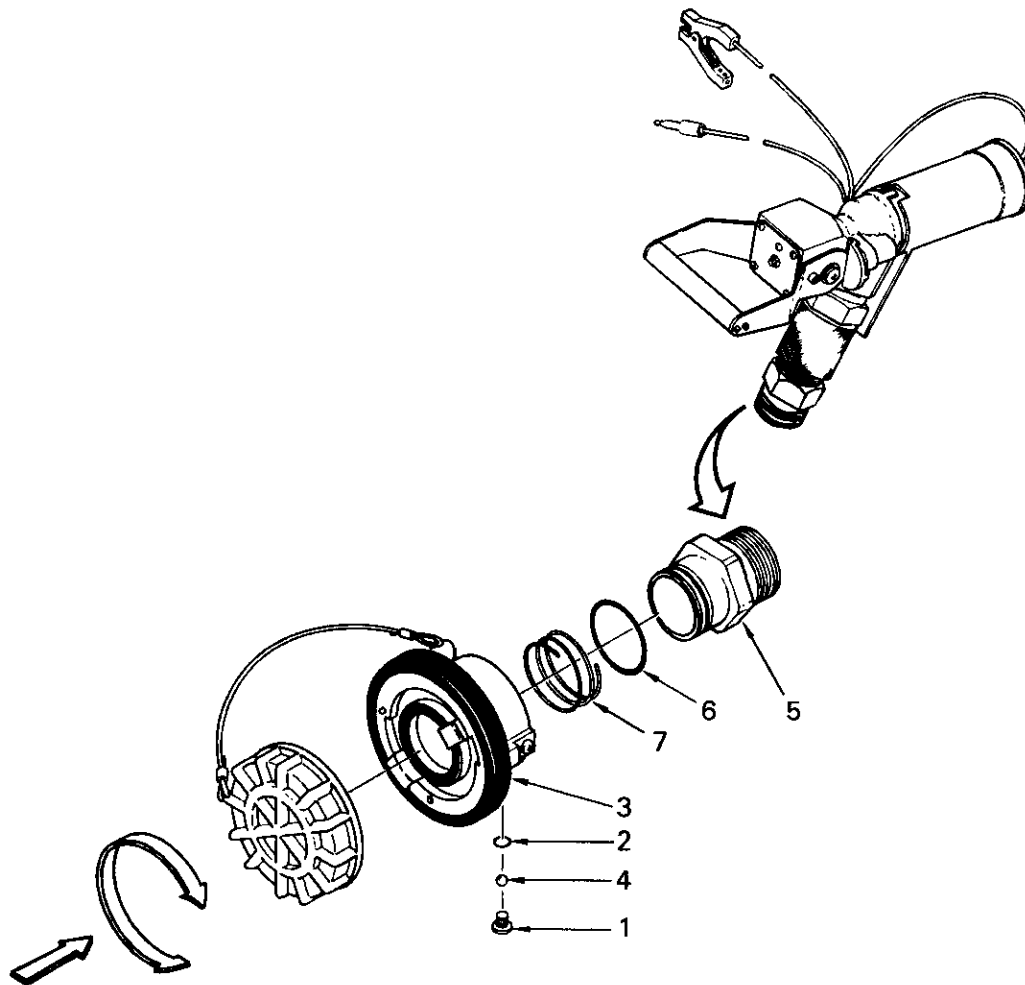

4.10B. REPAIR UNISEX COUPLING.

This task consists of: a. Disassembly b. Inspection c. Assembly

INITIAL SET-UP:

Tools:

Tool Kit, General Mechanics
(Item 1, Appendix B)

Materials/Parts Required:

None

General Safety Requirements:

WARNING

- Fuels are toxic and flammable. Do not get on person or clothing. Do not use near open flame. Area should be well ventilated.
- Using dry cleaning solvents incorrectly can cause injury or even death.
- Fuel is flammable. Do not smoke.

Equipment Condition:

Unisex coupling removed from CCR nozzle
(para. 4.10A.)

NOTE

Inspect the coupling components as they are disassembled. Repair is limited to replacement of unserviceable components discovered during disassembly.

a. Disassembly and Inspection.

- (1) Remove spring (1) from unisex coupling (2).
- (2) If the dust cap (3) or cable (4) is to be replaced, cut cable (4) to remove.
- (3) The ring (5) attaching cable (4) to unisex coupling (2) may be removed from the cable (4) by rotating it through the split portion of the ring (5).
- (4) Remove the bumper (6) only if it is to be replaced or the lugs (7 and/or 8) must be replaced.
- (5) Remove screws (9) to remove lugs (7 and/or 8).
- (6) Remove locking pin (10) and spring (11).

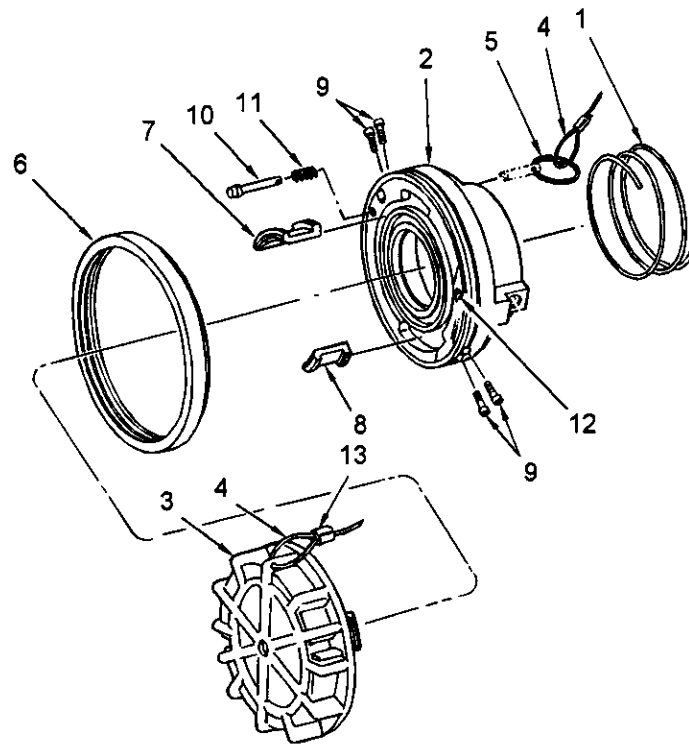
4.10B. REPAIR UNISEX COUPLING - continued.**NOTE**

Do not remove continuity ball (12) from unisex coupling body. If continuity ball requires replacement, the entire unisex coupling must be replaced.

b. Assembly.

- (1) Install locking pin (10) and spring (11).
- (2) Install lugs (7 and/or 8) with screws (9).
- (3) Install bumper (6) onto coupling body such that the tapered edge is facing the unisex coupling (2) body.
- (4) Attach cable (4) to dust cap (3) by looping about 6 inches of cable through the hole in dust cap (3) forming a loop back on the cable (4). Install and crimp a sleeve (13) over the two sections of cable (4).
- (5) If cable (4) was cut, attach cable (4) to split ring (5) by looping about 6 inches of cable through the ring (5) forming a loop back on the cable (4). Install and crimp a sleeve (13) over the two sections of cable (4). If cable (4) was not cut, attach to split ring (5) by rotating split ring (5) through cable (4) loop.
- (6) Install spring (1) in unisex coupling (2).

Section V. PREPARATION FOR STORAGE OR SHIPMENT

4.11. SECURITY PROCEDURES.

Refer to AR 190-11 or AR 190.13

4.12. PREPARATION FOR MOVEMENT.

NOTE

For disposal of contaminated fuel, refer to FM 10-20, Organizational Maintenance of Military Petroleum Pipelines, Tanks and Related Equipment.

Disconnect CCR Nozzle From Fuel Supply.

- (1) Disconnect CCR Nozzle (2) from aircraft (para 2-9).
- (2) Shut down fuel system. Refer to TM 10-4930-247-13&P.
- (3) Close valve on fuel hose coupling (6). Refer to TM 10-4930-247-13&P.
- (4) Verify that handle (1) on CCR Nozzle (2) is in the CLOSE (back) position.
- (5) Disconnect dust cover (3) from dust cover (5).
- (6) While pulling up on lanyard attached to dust cover (3), twist and disconnect inlet coupling (4) from coupling (6) on fuel hose (7).
- (7) Drain residual fuel from CCR Nozzle (2).
- (8) Install dust cover (3) on inlet coupling (4).
- (9) Install dust cover (5) on fuel hose coupling (6).
- (10) The CCR Nozzle is now ready to be placed in a suitable container. For additional information on Packaging of Army Material for Shipment and Storage, refer to AR 746-1.

4-12. PREPARATION FOR MOVEMENT - continued.

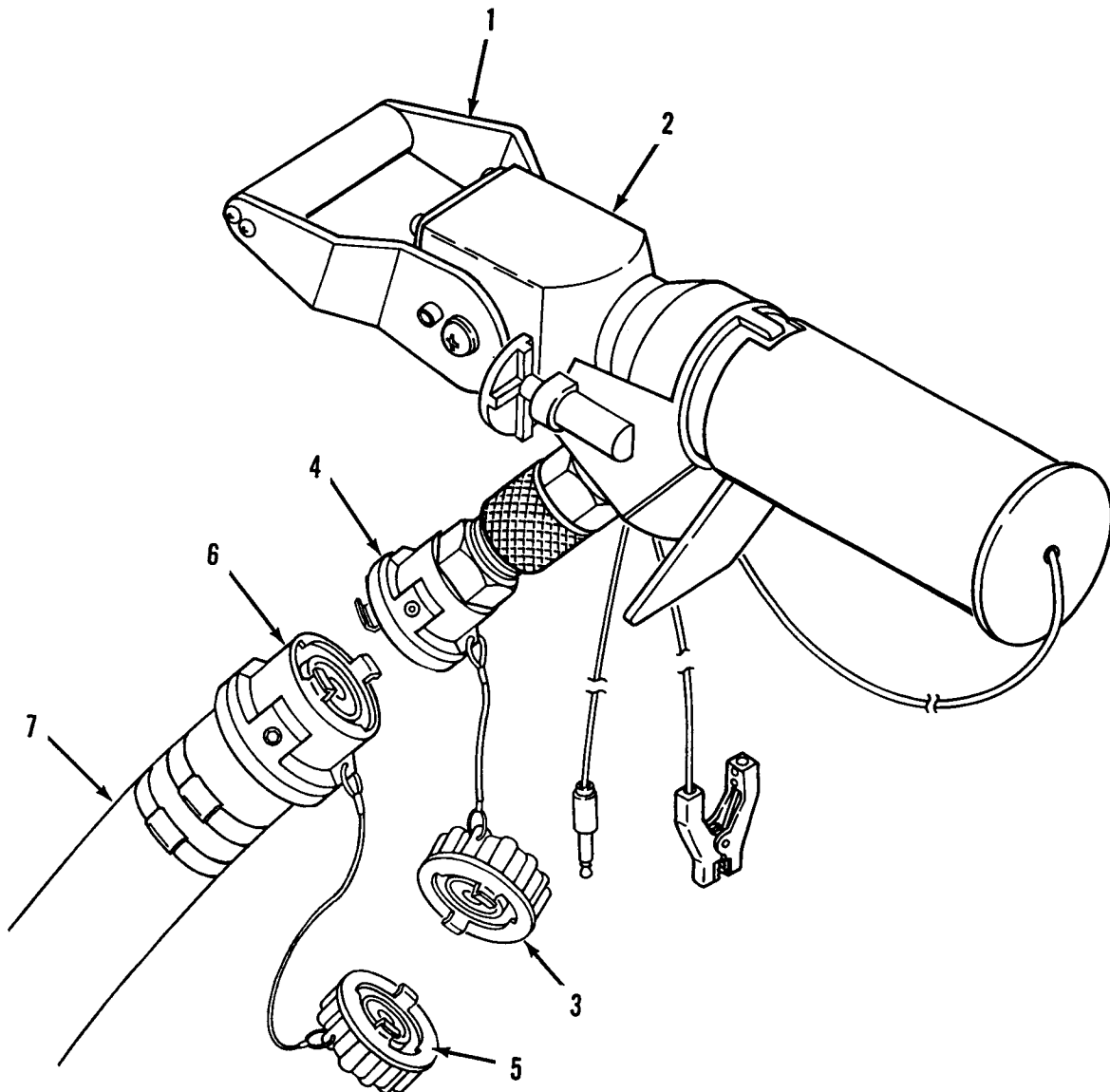

4-13. ADMINISTRATIVE STORAGE.

Placement of equipment in administrative storage should be for short periods of time when a shortage of maintenance effort exists. Items should be in mission readiness within 24 hours or within the time factors as determined by the directing authority. During the storage period, appropriate maintenance records will be kept.

Before placing the equipment in administrative storage, current preventive maintenance checks and services should be completed, shortcomings and deficiencies should be corrected, and all Modification Work Orders (MWO) should be applied.

Storage site selection. Inside storage is preferred for items selected for administrative storage. If inside storage is not available, trucks, vans, conex containers, and other containers may be used.



CHAPTER 5

DIRECT SUPPORT MAINTENANCE INSTRUCTIONS

PARAGRAPH	TITLE	PAGE
Section I.	Direct Support Troubleshooting	5-1
Section II.	Direct Support Maintenance Instructions	5-1
5-1.	Introduction	5-1
5-2.	CCR Nozzle Assembly Repair	5-2
5-3.	CCR Nozzle, Piston Model, Assembly Repair	5-22

Section I. DIRECT SUPPORT TROUBLESHOOTING

Troubleshooting is not required on the CCR Nozzle at Direct Support level of maintenance.

Section II. DIRECT SUPPORT MAINTENANCE INSTRUCTIONS

5-1. INTRODUCTION.

This section contains Direct Support level maintenance procedures for the CCR Nozzle.

Maintenance consists of repair by replacement of defective components, then testing to ensure correction of malfunction.

5-2. CCR NOZZLE ASSEMBLY REPAIR.

This task consists of: a. Disassembly b. Repair c. Assembly d. Testing

INITIAL SET-UP:

Tools:

- Tool Kit, General Mechanics (Item 1, Appendix B)
- Body Wrench (Item 5, Appendix B)
- Diaphragm Carrier Wrench (Item 6, Appendix B)
- Piston Compression Tool (Item 7, Appendix B)
- Locking Lug Assembly Tool (Item 8, Appendix B)
- Poppet Wrench (Item 9, Appendix B)
- Dial Caliper (Item 4, Appendix B)
- Wrench 2½" (Item 4, Appendix B)
- Vise (with soft faced jaws) (Item 4, Appendix B)
- Torque Wrench (Item 4, Appendix B)

Materials/Parts Required:

- Rags (Item 2, Appendix F)
- Solvent (Item 1, Appendix F)
- Bushing (Item 2, Appendix J)
- Alcohol, Rubbing (Item 5 Appendix F)
- Silicone Compound (Item 3, Appendix F)
- Sealing Compound (Item 4 , Appendix F)
- Diaphragm Assembly (Item 3, Appendix J)
- Seal, Sleeve (Item 4, Appendix J)
- Seal, Wiper (2 each) (Item 5, Appendix J)
- Packing, Preformed (Item 6, Appendix J)

General Safety Requirements:

WARNING

- Fuels are toxic and flammable. Do not get on person or clothing. Do not use near open flame. Area should be well ventilated. **DO NOT SMOKE.**
- Using drycleaning solvents incorrectly can cause injury or even death.

Equipment Condition:

Nozzle removed from fuel system (refer to system T.M.).

a. Disassembly.

- (1) Push the piston compression tool into the nozzle discharge end until it latches in place.
- (2) Push in latch activator (15) and move handle (8) to OPEN position.

WARNING

End cover is under spring pressure. Keep pressure on end cover while removing screws.

- (3) Carefully remove four screws (1) and remove end cover (2).
- (4) Screw (3) and lock pin (4) should not be removed unless damaged. If damaged, use a soft jaw chuck or vise to hold locking pin (4) in place and remove screw (3).
- (5) Remove spring retainer (5) and spring (6).
- (6) Remove four handle screws (7) and handle (8).

5-2. CCR NOZZLE ASSEMBLY REPAIR - continued.

a. Disassembly - continued.

- (7) On the nozzle left side, remove screw (9), one washer (10), bushing (11) and side plate (12). Remove bushing (11) and washer (10) from screw (9). Remove second washer (10) from housing (17).
- (8) On the right side of nozzle loosen screw (9) only.
- (9) While compressing valve latch actuator (15) on right side of nozzle, remove screw (9), one washer (10), bushing (11) and side plate (12). Remove bushing (11) and washer (10) from screw (9). Remove second washer (10) from housing (17).
- (10) Slowly release latch actuator (15) and remove along with spring (16) from housing (17).

NOTE

Do not remove screw and actuating cam from side plate unless damaged and replacement is required.

- (11) Hold the actuating cam (14) in place with a soft jaw chuck or vise and remove screw (13) from side plate (12).

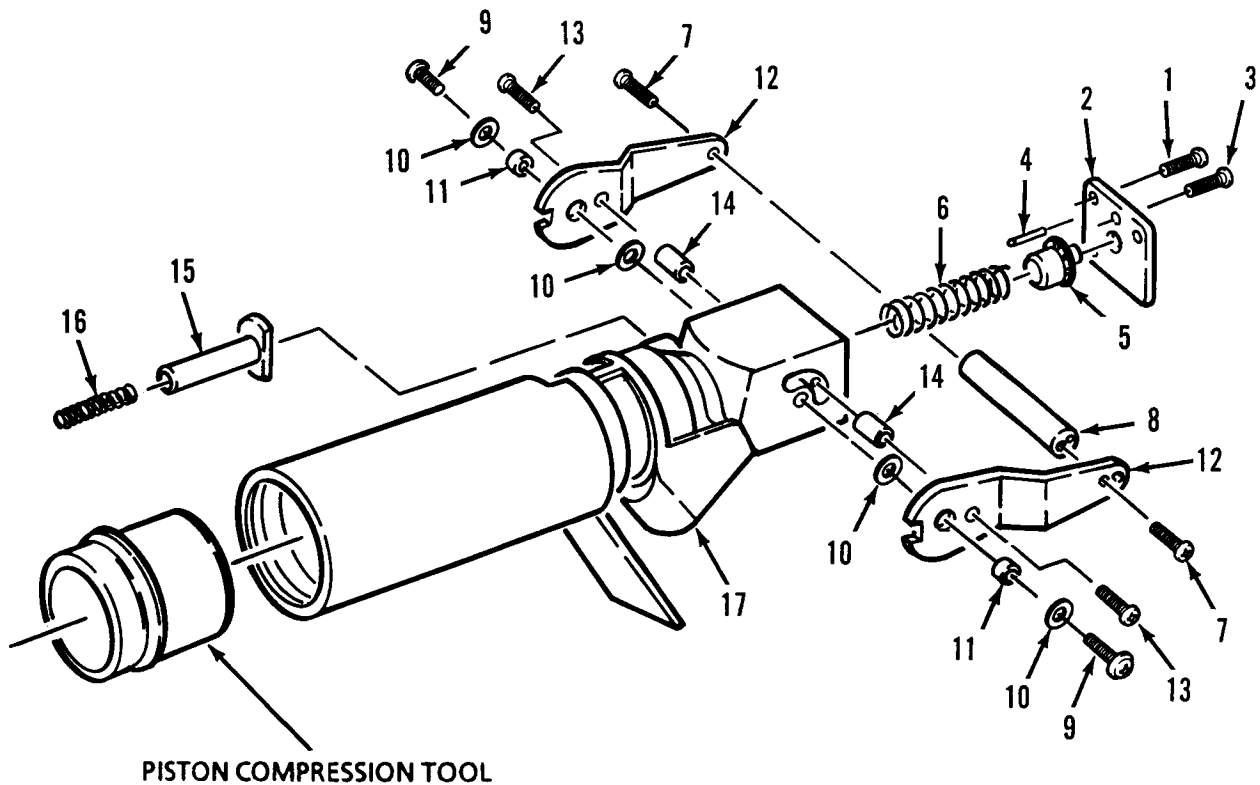

5-2 . CCR NOZZLE ASSEMBLY REPAIR - continued.

a. Disassembly - continued.

- (12) Unscrew valve actuating ring (18) from diaphragm assembly (20) and remove.
- (13) Secure diaphragm carrier wrench in a vise. Position nozzle on carrier wrench and slowly turn until the nozzle seats itself on wrench. Using the poppet wrench at the front of the nozzle, unscrew poppet (23). Remove poppet wrench from nozzle, nozzle from diaphragm carrier wrench and wrench from vise.
- (14) Remove six screws (19) from housing (17) that secure the diaphragm retainer (21).
- (15) Remove the diaphragm assembly (20) together with diaphragm retainer (21) and the flow indicator (22).
- (16) Remove the diaphragm retainer (21) from diaphragm assembly (20).
- (17) Unscrew and remove the flow indicator (22) from the diaphragm assembly (20). Discard diaphragm assembly.

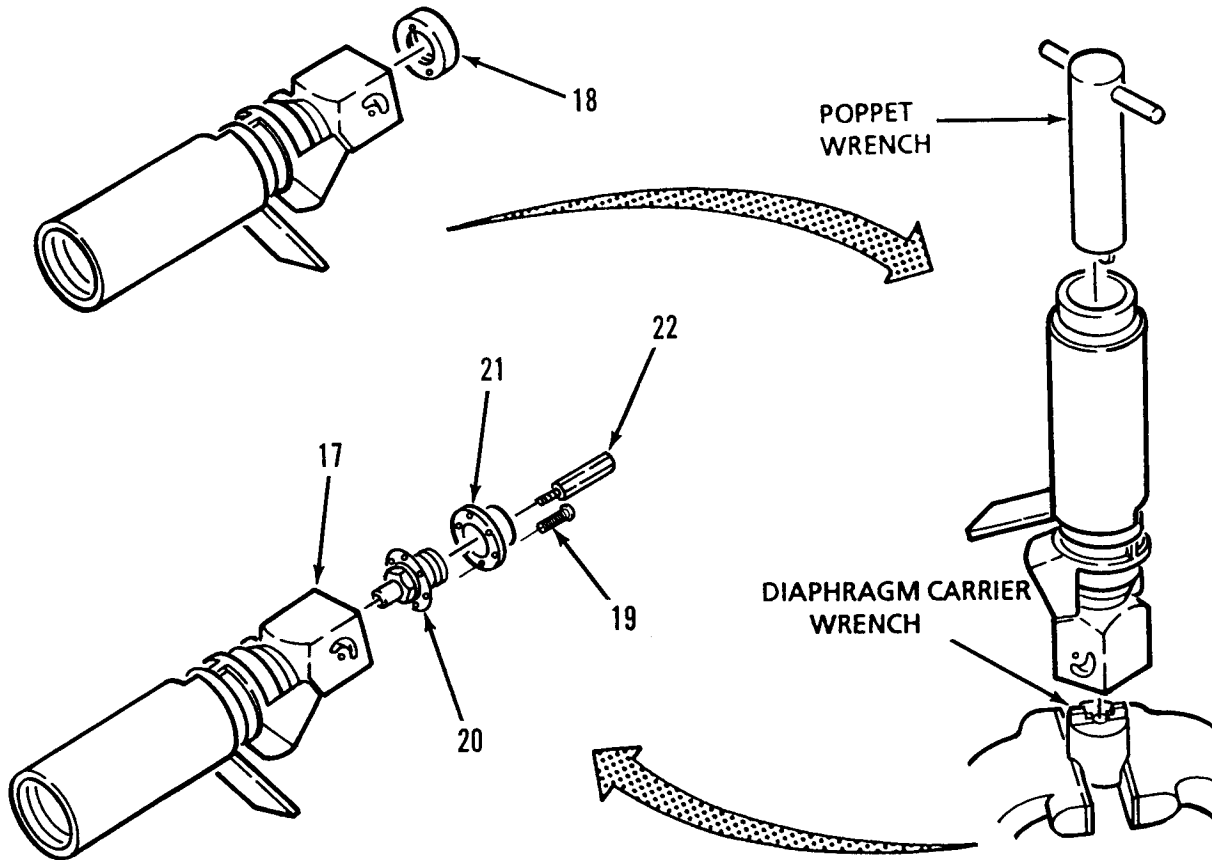

5-2. CCR NOZZLE ASSEMBLY REPAIR - continued.

- (18) While holding the piston compression tool, slowly pull back the collar (28). Spring (25) will push the piston compression tool, poppet (23) and sleeve seal (24) out of body (27).
- (19) Remove spring (25) and flow guide (26) from the nozzle discharge end.
- (20) Apply alcohol around collar (28) and body (27).
- (21) Place housing (17) into a soft face vise with discharge end facing up, and tighten only enough to prevent housing from turning or falling from vise.

CAUTION

Failure to trip the latch mechanism will result in damage to the stayback detents during following steps.

- (22) Aline the body wrench with the nine locking lugs (35) and press until the collar (28) trips in the forward position.

WARNING

Body is under spring pressure. Keep pressure on body wrench to prevent sudden separation.

CAUTION

To reduce the friction between the locking lugs and the collar, slightly pull back on the collar.

- (23) Turn the body wrench and loosen body (27) from the housing (17).

5-2. CCR NOZZLE ASSEMBLY REPAIR - continued.

a. Disassembly - continued.

- (24) While holding collar spring (29) and collar (28) together, remove collar (28) and collar spring (29) from housing (17).
- (25) Carefully place collar (28), with body wrench still attached, on a workbench with discharge end down.
- (26) Remove collar spring (29).
- (27) Remove collar (28).
- (28) Remove spring retainer (30) and stayback spring (31) from collar (28).
- (29) Remove lug retaining ring (32), nine locking lugs (33), three stayback detents (34) and lug wire (35) from body (27).
- (30) Remove two wiper seals (36) from body (27). Discard wiper seals.
- (31) Remove packing (37) from housing (17). Discard packing.
- (32) Unscrew strainer housing (38) from housing (17).

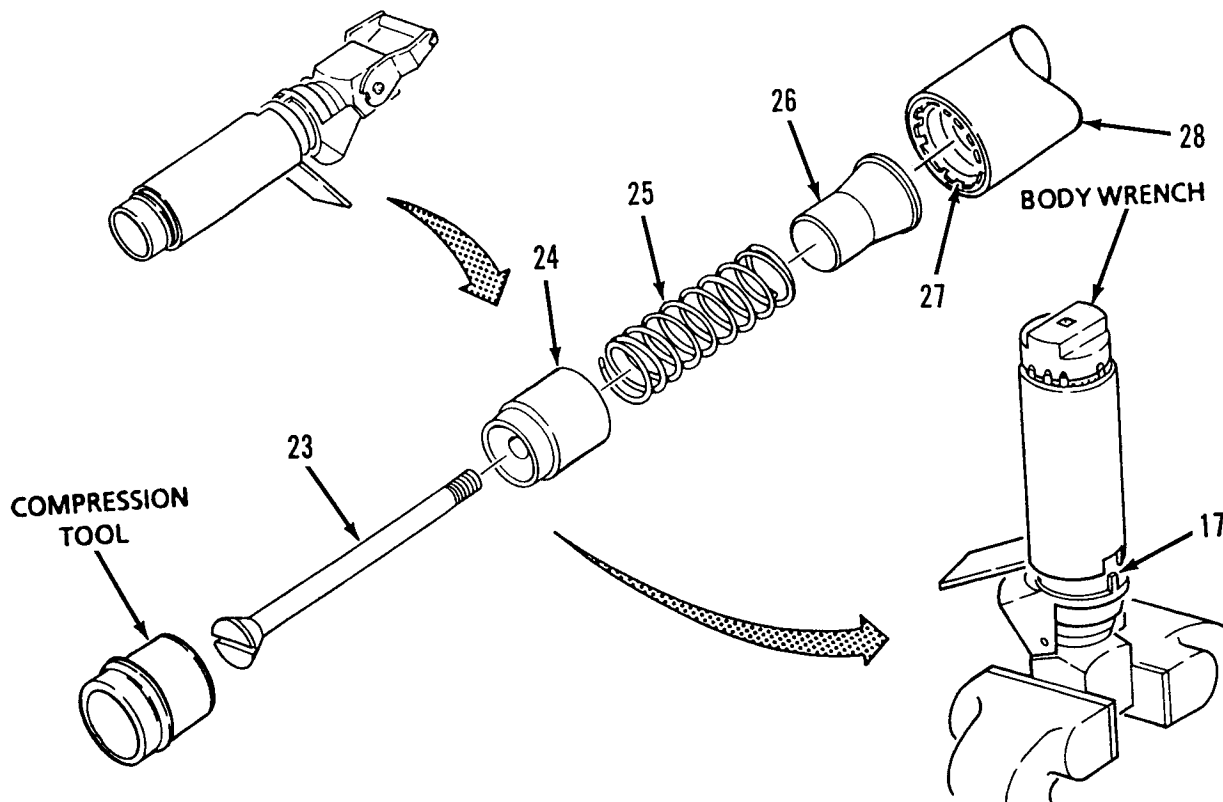

5-2. CCR NOZZLE ASSEMBLY REPAIR - continued.

a. Disassembly - continued.

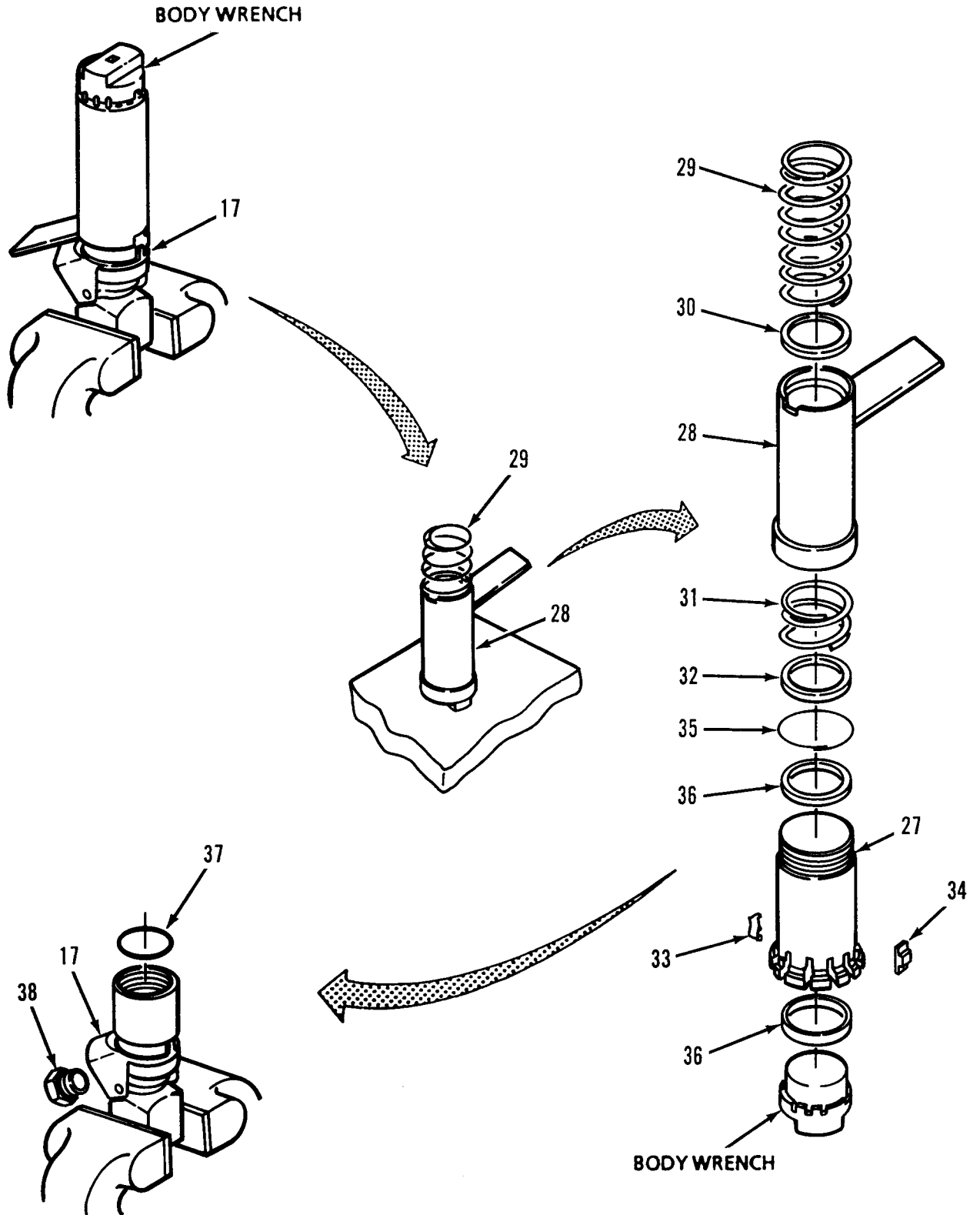

5-2. CCR NOZZLE ASSEMBLY REPAIR - continued.

b. Repair.

WARNING

Drycleaning solvent, P-D-680 Type III, used to clean parts is potentially dangerous to personnel and property. Use in a well-ventilated area as the fumes are dangerous if inhaled. Avoid repeated and prolonged skin contact. Do not use near open flame or excessive heat. Flash point of solvent is 138°F.

- (1) Clean all components removed using a wiping rag moistened with drycleaning solvent. Dry with a clean, dry wiping rag.
- (2) Inspect all parts for damage. Look for damaged threads, broken, worn, scored, or deformed parts, cracks or corrosion.
- (3) Replace damaged or defective components.

c. Assembly.

- (1) Place lug assembly tool in vise.
- (2) Lubricate two wiper seals (36) with silicone compound and install into nozzle body (27) in the internal groove closest to the threaded end. Make sure the seals are fully seated toward the slotted end and the open end of the U shape is facing out toward the threaded end of body (27).

CAUTION

Lug wire must be positioned so split is not over one of the slots in body.

- (3) Install lug wire (35) into the lower groove on body (27) and insert body onto the lug assembly tool.

NOTE

Stayback detents aline with grooves in body and the three slots in the lug assembly tool. The detents are placed behind lug wire.

- (4) Install three stayback detents (34) on body (27).
- (5) Insert nine locking lugs (33) onto lug wire (35). Aline locking lugs (33) with remaining grooves in body (27).

5-2. CCR NOZZLE ASSEMBLY REPAIR - continued.

c. Assembly - continued.

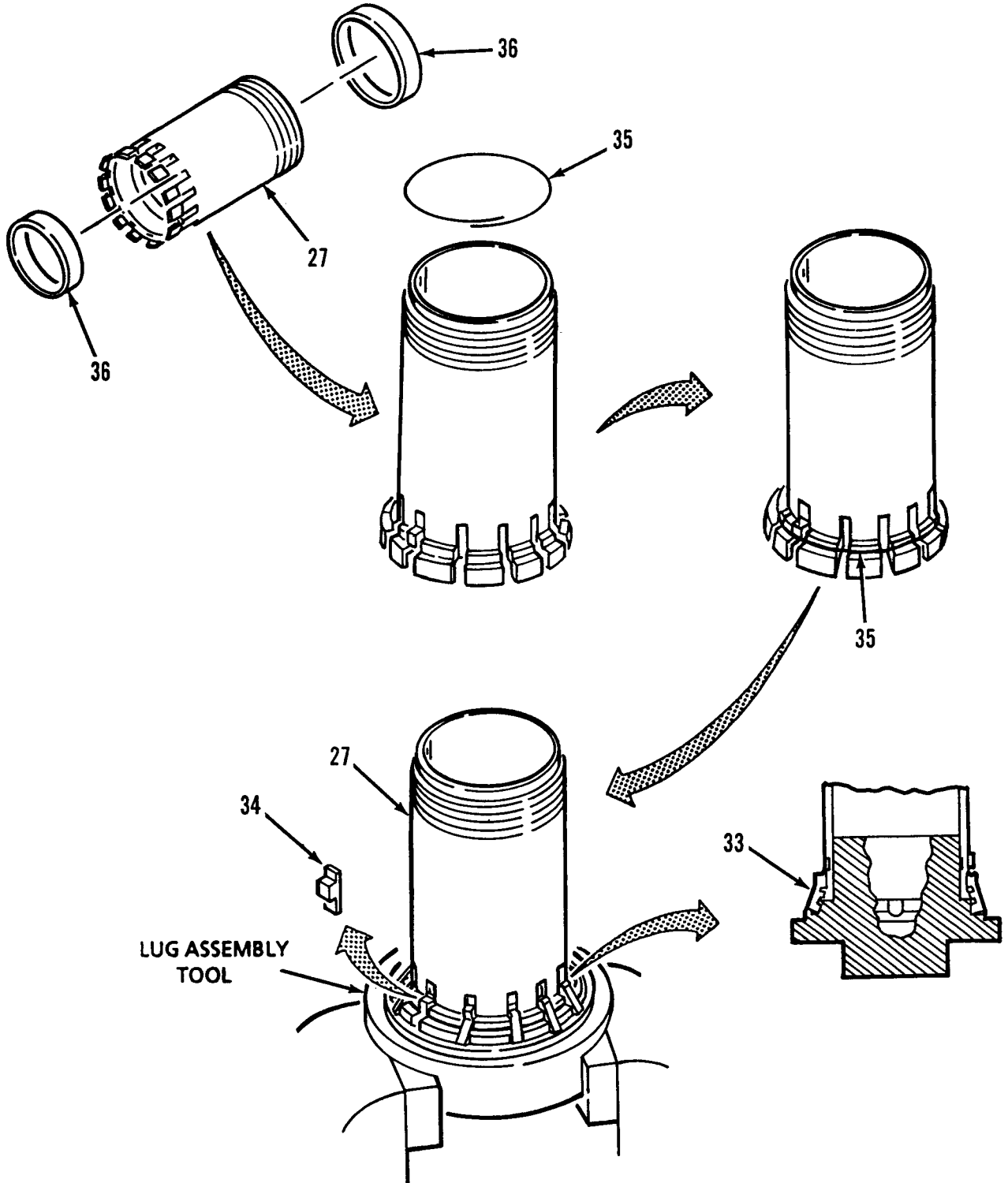

5-2. CCR NOZZLE ASSEMBLY REPAIR - continued.

c. Assembly - continued.

- (6) Install lug retainer ring (32) onto body (27) with beveled end of ring facing locking lugs (33).
- (7) Lubricate threads on body (27) with silicone compound.
- (8) Install stayback spring (31) onto body (27).
- (9) Install collar (28) over body (27), down over the locking lugs (33) and stayback detents (34).
- (10) Install spring retainer (30) with groove facing down and collar spring (29) on body (27).

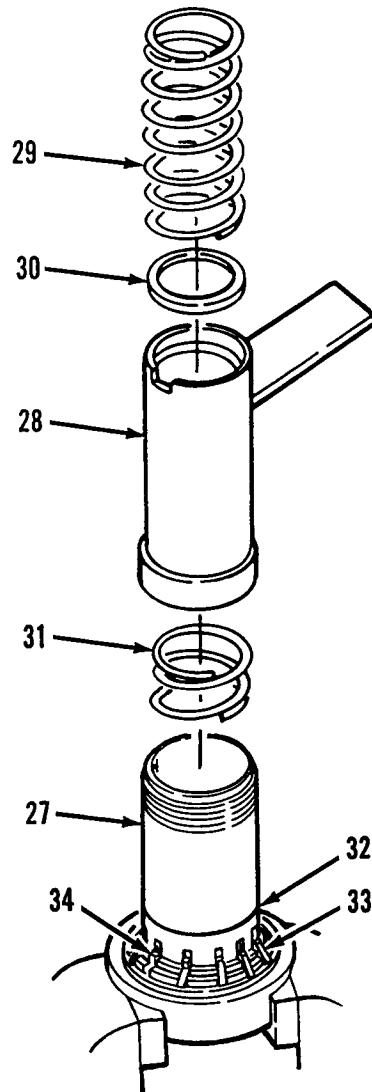

5-2. CCR NOZZLE ASSEMBLY REPAIR - continued.

c. Assembly - continued.

- (11) Lubricate packing (37) with silicone compound and install into housing (17).
- (12) Slide housing (17) into collar (28). Align the notch on the collar with the tap on top of housing.

CAUTION

Using the lug assembly tool to tighten body. Use the body wrench to complete the tightening process.

- (13) Push down on housing (17) and rotate clockwise until tab contacts the collar (28). Rotate housing (17) counterclockwise until notch and tab are aligned.
- (14) Remove the assembled components from lug assembly tool and remove tool from vise.

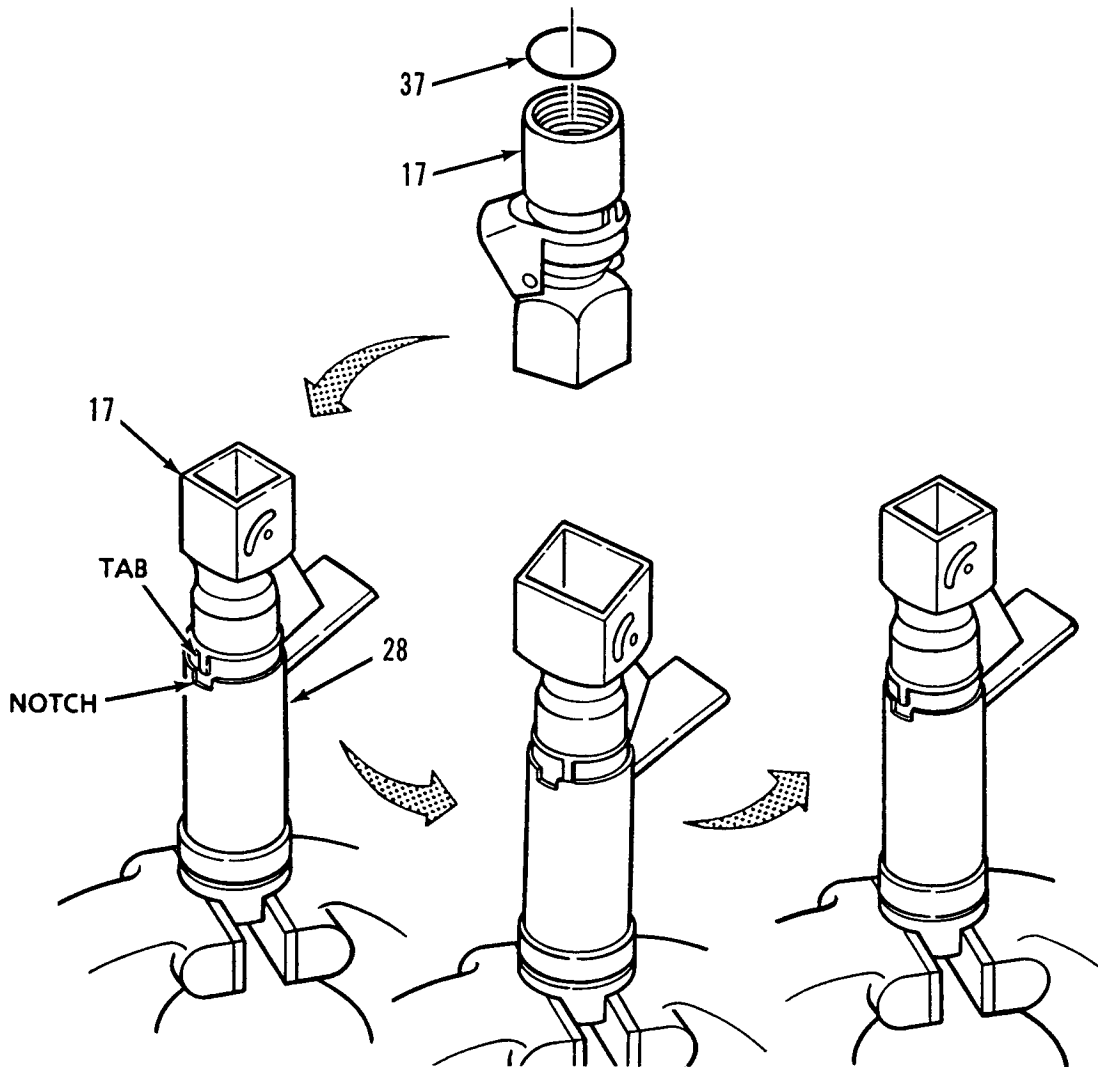

5-2. CCR NOZZLE ASSEMBLY REPAIR - continued.

c. Assembly - continued.

- (15) Place housing (17), with discharge end facing up, into a soft face vise and tighten only enough to prevent housing from turning or falling from vise.
- (16) Aline body wrench with nine locking lugs and press down until the collar (28) trips in the forward position.

CAUTION

To reduce the friction between the locking lugs and the collar, slightly pull back on the collar.

NOTE

Always aline the slot in the collar and the tab on the housing.

- (17) Tighten the assembly to 300 in-lb.
- (18) Pull back on collar (28) to release the body wrench, remove body wrench. Remove nozzle assembly from vise.

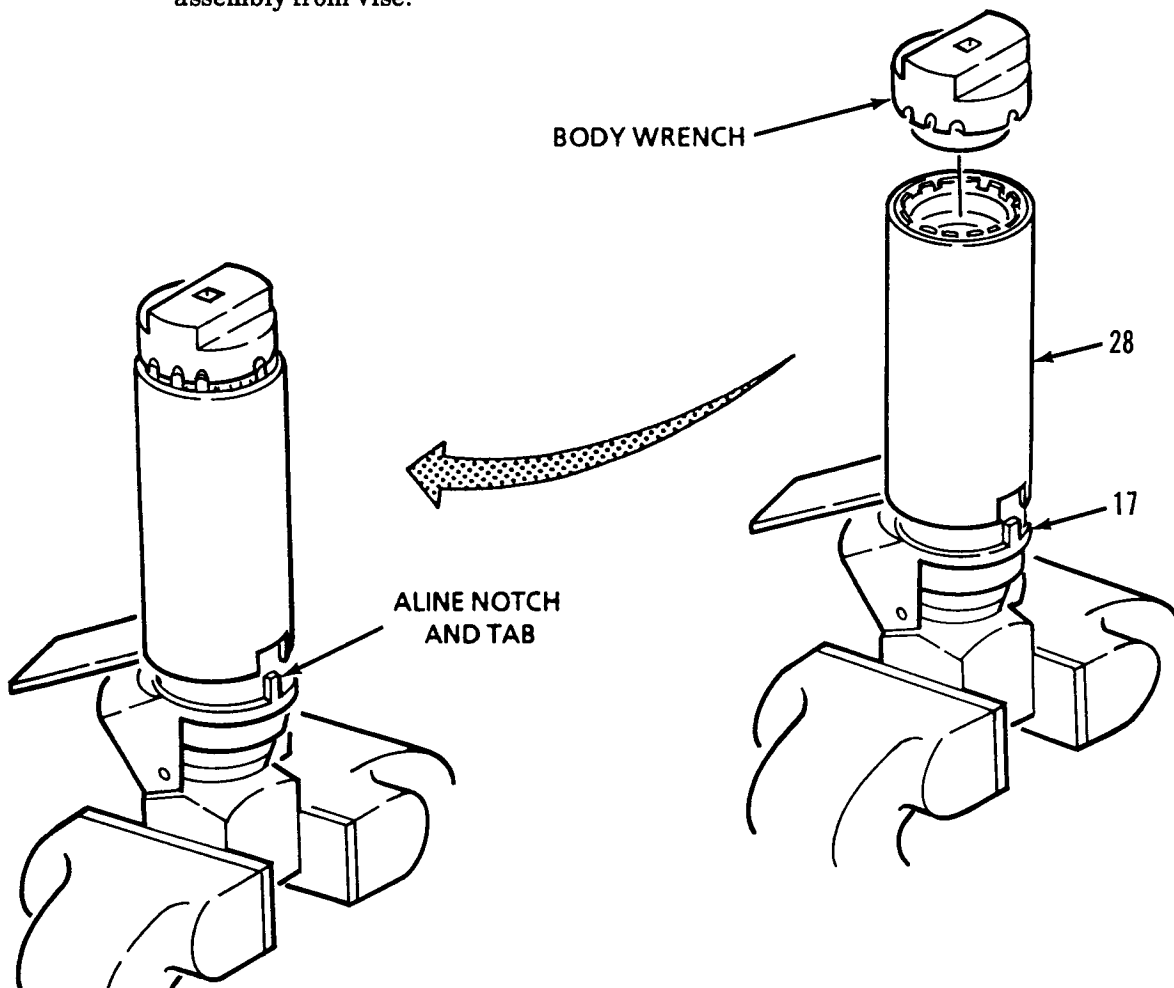

5-2. CCR NOZZLE ASSEMBLY REPAIR - continued.

c. Assembly - continued.

- (19) Install the flow indicator (22) on diaphragm assembly (20).
- (20) Prepare diaphragm assembly (20) for installation by rolling the diaphragm until flange is alined with brass ring.
- (21) Position diaphragm retainer (21) over diaphragm assembly (20) and insert into housing (17).
- (22) Secure diaphragm retainer (21) to housing (17) using six screws (19) as follows:
 - (a) Tighten six screws (19) in the sequence shown.
 - (b) Using a torque wrench , tighten screw in position 1 to 15 in-lb. Repeat in order for screws in positions 5, 3, 6, 4, and 2.
 - (c) Repeat step (b), tightening to a torque of 20 in-lb.
 - (d) Repeat step (b) tightening to a torque of 25 in-lb.

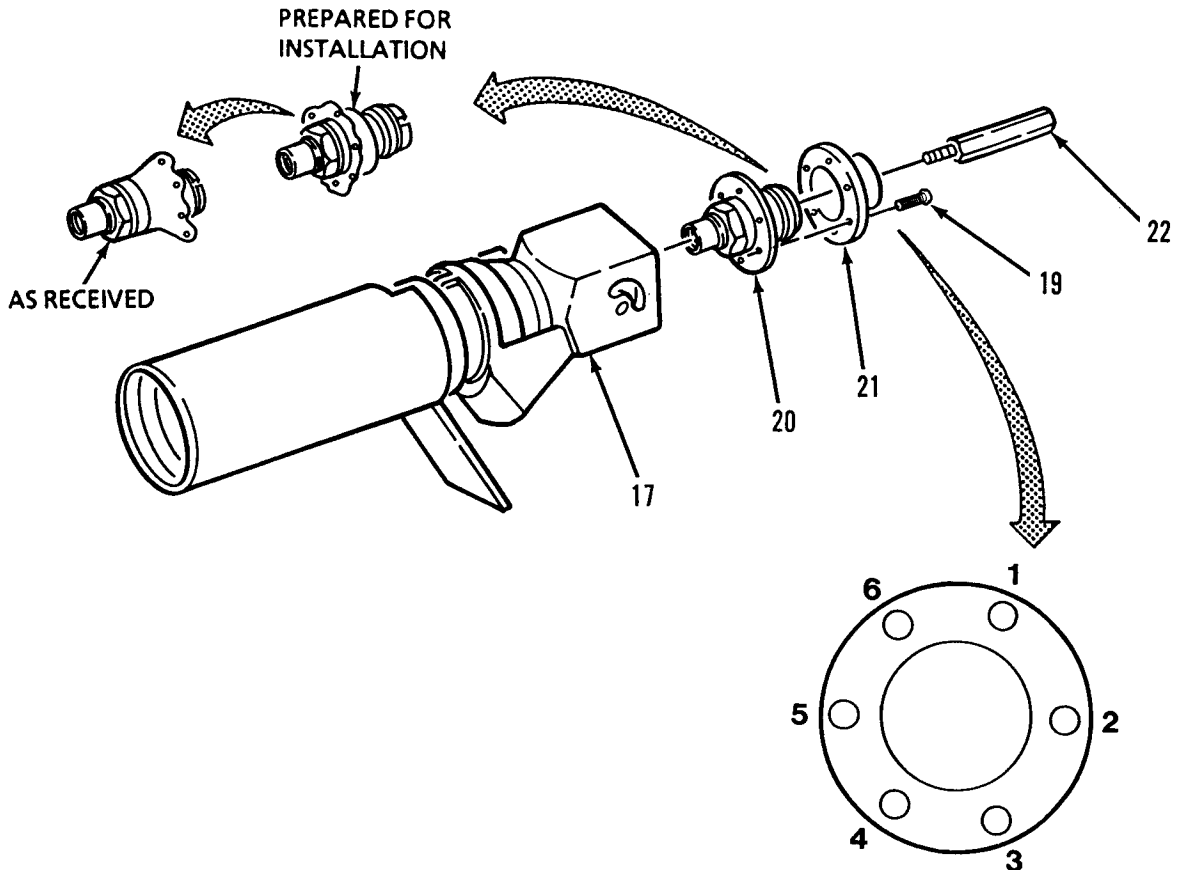

5-2. CCR NOZZLE ASSEMBLY REPAIR - continued.

c. Assembly - continued.

- (23) Insert flow guide (26), valve spring (25) and sleeve seal (24) into housing (17). Push sleeve seal and valve spring down with compression tool until the tool locks onto the collar (28).

WARNING

During assembly, components are under spring pressure, injury possible. If collar is pushed/pulled to the rear, piston tool and sleeve will be discharged under pressure. Do not push/pull the collar the the rear. Do not remove the piston removal tool until assembly is complete.

- (24) Install diaphragm carrier wrench into vise. Position square end of housing (17) on carrier wrench and slowly turn until housing seats itself on wrench.
- (25) Install poppet (23) through compression tool and tighten with the poppet wrench. Remove poppet wrench; and remove housing (17) from diaphragm carrier wrench; remove carrier wrench from vice.
- (26) Check diaphragm assembly (20) for movement by gently pulling flow indicator (22) until it stops, then release.
- (27) Install strainer housing (38) into housing (17).

5-2. CCR NOZZLE ASSEMBLY REPAIR - continued.

c. Assembly - continued.

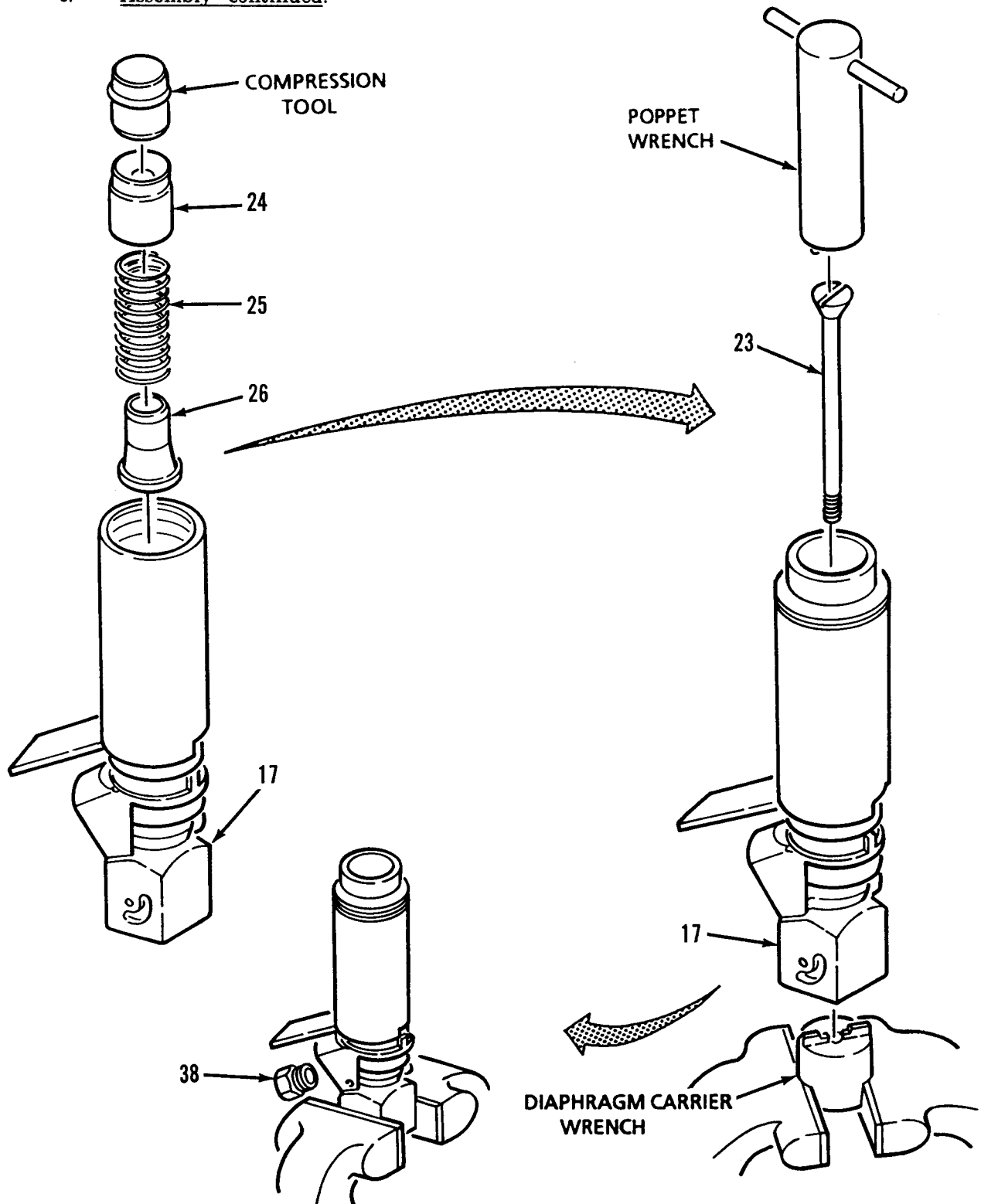

5-2. CCR NOZZLE ASSEMBLY REPAIR - continued.

c. Assembly - continued.

- (28) Using a soft jaw chuck or vise, assemble actuating cam (14) on the handle side plate (12) with screws (13), then torque screws to 150 in-lb. Repeat for remaining side plate (12).

NOTE

The actuating cam must be behind the diaphragm retainer inside the housing.

- (29) Place nozzle assembly into soft faced vise and position one washer (10) on housing (17) and insert the left side actuating cam (14) into the curved slot on housing (17) with the handle side plate (12) in the OPEN (up) position.
- (30) Insert bushing (11) into handle side plate (12); place second washer (10) on outside of handle side plate and secure to housing (17) with screw (9).. Tighten screw (9) to 135 - 150 in-lb torque.
- (31) Insert spring (16) and valve latch actuator (15) into housing (17) latch cavity (right side). Attach the right side handle side plate and parts as described in steps 30 and 31 while holding the latch actuator (15).
- (32) Mount the handle (8) between the two handle side plates (12) and secure with four screws (7). Tighten four screws (7) to 50 ± 5 in-lbs torque.
- (33) Install valve actuating ring (18) into housing (17) by screwing it onto the diaphragm assembly (21) until .105 - .135 inch of diaphragm assembly (21) shows past the valve actuating ring (18). Use dial caliper to verify the .105 - .135 inch requirement. Holes in valve actuating ring should be in the OPEN/CLOSED position.
- (34) Install regulator spring (6) and spring retainer (5) into housing (17) over flow indicator.

NOTE

Lock pin can be either toward the top or bottom of housing.

- (35) Carefully install lock pin (4) on end plate (2) using a soft jaw chuck or vise with screw (3).
- (36) Position end plate (2) on housing (17). Ensure lock pin (4) is in valve actuating ring (18) and the spring retainer (5) is positioned in the center hole.

WARNING

End cover is under spring pressure. Keep pressure on end cover while installing screws.

- (37). Secure end plate (2) to housing (17) with four screws (1).
- (38) Place handle (8) in the CLOSED position and pull collar (28) to remove piston compression tool.

5-2. CCR NOZZLE ASSEMBLY REPAIR - continued.

c. Assembly - continued.

NOTE

If strainer components and ground cables were removed, assemble (ref. 4-10).

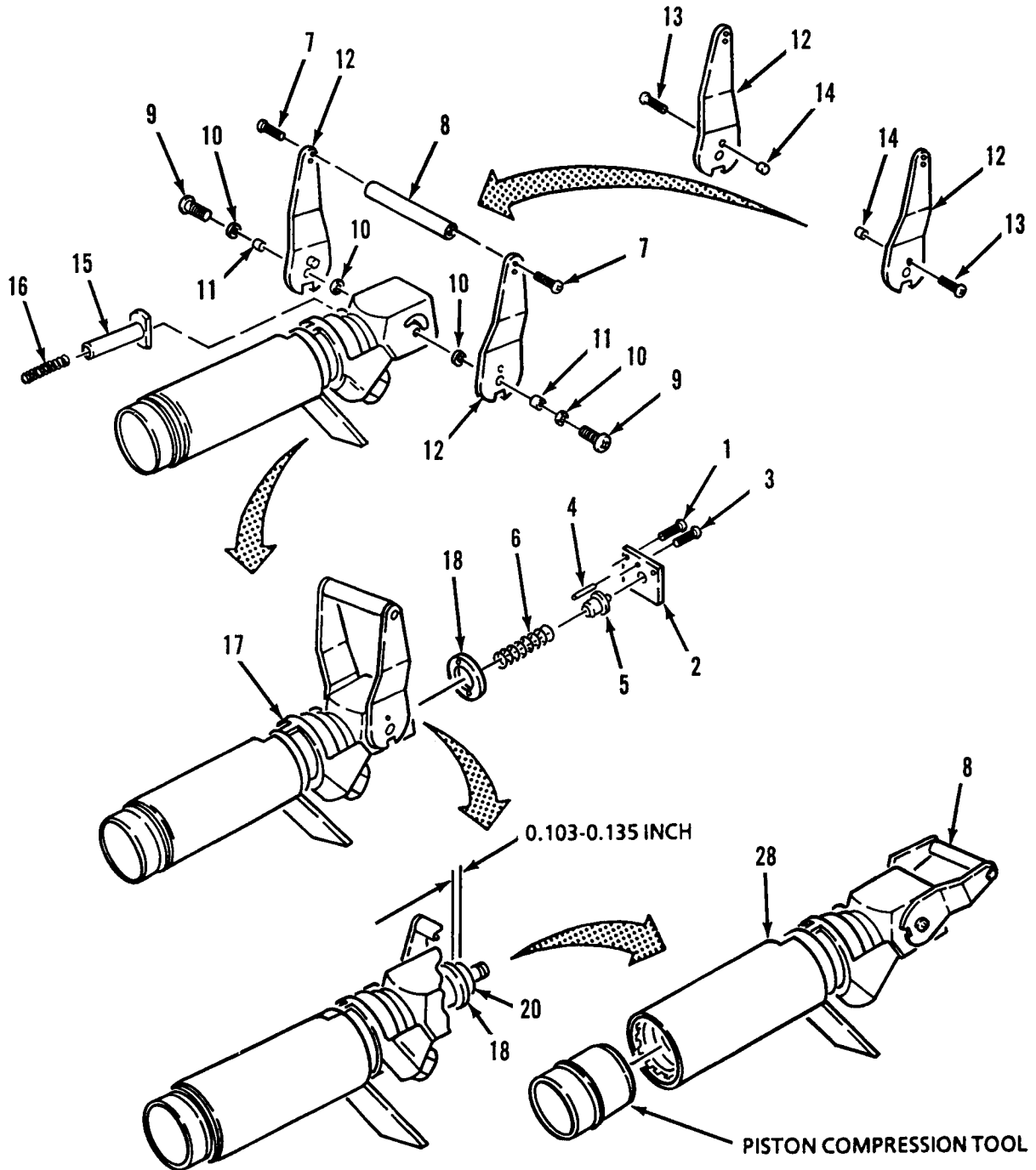

5-2. CCR NOZZLE ASSEMBLY REPAIR - continued.

- d. Testing. After repair, the CCR Nozzle should be tested to ensure proper operation. A typical setup for testing is shown.

WARNING

Drycleaning solvent, AA 711 Types I and II, used to clean parts is potentially dangerous to personnel and property. Use in a well-ventilated area as the fumes are dangerous if inhaled. Avoid repeated and prolonged skin contact. Do not use near open flame or excessive heat. Flash point of solvent is 130°F.

NOTE

There shall be no evidence of leakage during flow conditions, binding, valve chatter, distortion, or requiring excessive force at connecting and disconnecting of the nozzle to the test adapter.

- (1) **Functional Test.**
 - (a) Position nozzle handle (1) in the CLOSED (no flow) position and connect nozzle to test adapter outlet (2) and test adapter inlet (3).
 - (b) Open valve (8).
 - (c) Adjust pump (5) to 25 psig at nozzle inlet gage (4).
 - (d) Move nozzle handle (1) to the OPEN (flow) position to start flow.
 - (e) Close valve (8). Flow indicator at back of nozzle assembly (9) should be visible, indicating flow has stopped.
 - (f) Move nozzle handle (1) to the CLOSED (no flow) position.
 - (g) Open valve (8).
 - (h) Increase pump (5) pressure to 65 psig at nozzle inlet gage (4).
 - (i) Slowly open the nozzle (1) handle to the OPEN (flow) position.
 - (j) Close valve (8). Flow indicator at back of nozzle assembly (9) should be visible, indicating flow has stopped.
 - (k) Move nozzle handle (1) to the CLOSED (no flow) position.
 - (l) Remove nozzle assembly (9) from test adapter outlet (2). There should be no leakage from discharge end of nozzle.
 - (m) Reduce pump (5) pressure to zero psig at gage (4).
 - (n) Disconnect nozzle assembly (9) from test adapter inlet (3) and install dust caps.

5-2. CCR NOZZLE ASSEMBLY REPAIR - continued.

d. Testing - continued.

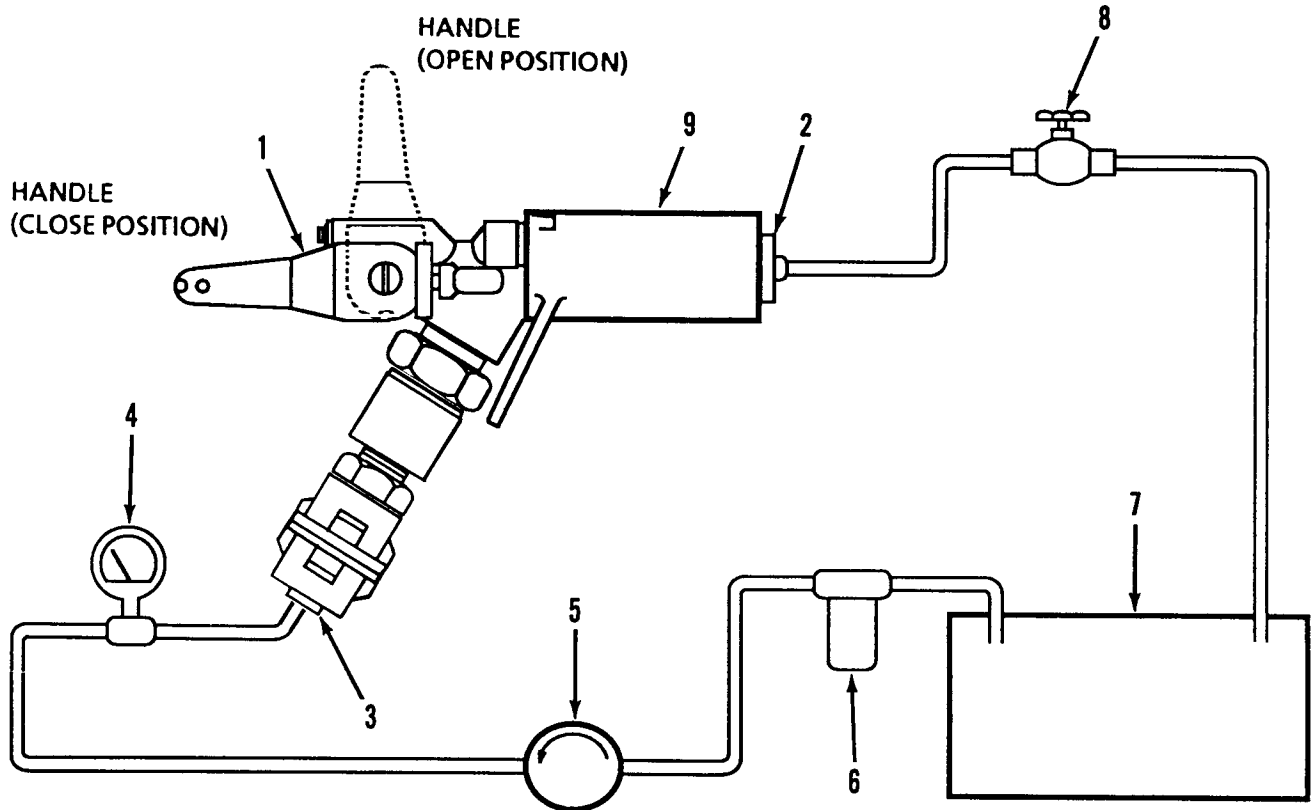

1. NOZZLE HANDLE
2. TEST ADAPTER, OUTLET
3. TEST ADAPTER, INLT
4. PRESSURE GAUGE, 0-300 PSIG.
5. HYDRAULIC PUMP, 0-300 PSIG.
6. FILTER, 15 MICRON
7. FLUID RESERVOIR, 10-20 GALLON.
8. 3/4 INCH MANUAL SHUTOFF VALVE - SEE NOTE 2.
9. NOZZLE ASSEMBLY

NOTES:

1. 3/4" NPT TAPPED HOLE IN BOTH ADAPTERS FOR HOSE CONNECTIONS.
2. SHUTOFF VALVE MUST BE POSITIONED HIGHER (ABOVE) THAN NOZZLE.

5-2. CCR NOZZLE ASSEMBLY REPAIR - continued.

d. Testing - continued.

WARNING

Drycleaning solvent, P-D-680 Type III, used to clean parts is potentially dangerous to personnel and property. Use in a well-ventilated area as the fumes are dangerous if inhaled. Avoid repeated and prolonged skin contact. Do not use near open flame or excessive heat. Flash point of solvent is 138°F.

NOTE

There shall be no evidence of leakage during flow conditions, binding, valve chatter, distortion, or requiring excessive force at connecting and disconnecting of the nozzle to the test adapter.

- (2) Pressure test with nozzle in the OPEN (flow) position.
 - (a) Position nozzle handle (1) in the CLOSED (no flow) position and connect nozzle assembly (9) to test adapter outlet (2) and test adapter inlet (3).
 - (b) Close valve (8) and move nozzle handle (1) to the OPEN (flow) position.
 - (c) Adjust pump (5) to 5 psig at the nozzle inlet gage (4) and maintain pressure for 1 minute minimum.
 - (d) Slowly increase pump (5) pressure to 90 psig at gage (4) and maintain pressure for 1 minute minimum.
 - (e) Reduce pump (5) pressure to 20 psig and open valve (8).
 - (f) With nozzle handle (1) in the OPEN (flow) position, remove nozzle from adapter (2). There shall be no evidence of leakage from the nozzle discharge end.
 - (g) Move nozzle handle (1) to the CLOSED (no flow) position and reduce pump (5) pressure to zero.
- (3) Pressure test with nozzle in the CLOSED (no flow) position.
 - (a) Move nozzle handle (1) to the CLOSED (no flow) position.
 - (b) Disconnect Nozzle (1) from test adapter outlet (2).
 - (c) Adjust pump (5) to 5 psig at the nozzle inlet gage (4) and maintain pressure for 1 minute minimum.
 - (d) Slowly increase pump (5) pressure to 90 psig at gage (4) and maintain pressure for 1 minute minimum.
 - (e) Reduce pump (5) pressure to zero.

5-2. CCR NOZZLE ASSEMBLY REPAIR - continued.

d. Testing - continued.

- (f) Move nozzle handle (1) to the OPEN (flow) position.
- (g) Adjust pump (5) to 5 psig at the nozzle inlet gage (4) and maintain pressure for one minute minimum.
- (h) Slowly increase pump (5) pressure to 90 psig at gage (4) and maintain pressure for one minute minimum.
- (i) Reduce pump (5) pressure to zero.
- (j) Move nozzle handle (1) to the CLOSED (no flow) position; disconnect nozzle assembly (9) from test adapter (3) and install dust caps.

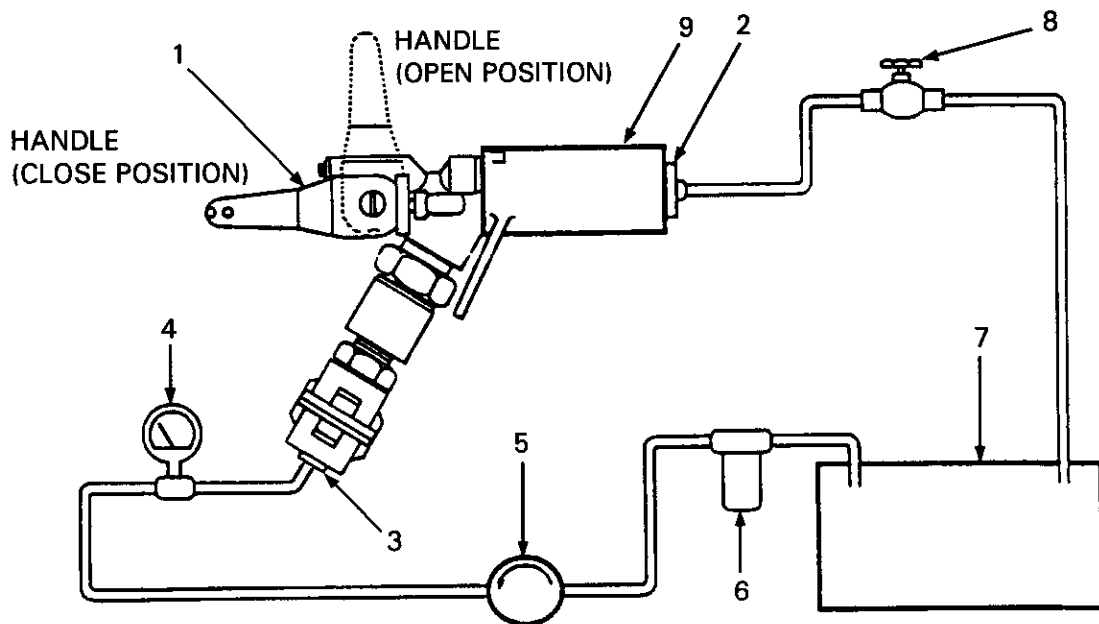

- 1. NOZZLE HANDLE
- 2. TEST ADAPTER OUTLET
- 3. TEST ADAPTER INLET
- 4. PRESSURE GAUGE, 0-300 PSIG
- 5. HYDRAULIC PUMP, 0-300 PSIG
- 6. FILTER, 15 MICRON
- 7. FLUID RESERVOIR, 10-20 GALLON
- 8. 3/4 INCH MANUAL SHUTOFF VALVE - SEE NOTE 2
- 9. NOZZLE ASSEMBLY

NOTES:

- 1. 3/4" NPT TAPPED HOLE IN BOTH ADAPTERS FOR HOSE CONNECTIONS
- 2. SHUTOFF VALVE MUST BE POSITIONED HIGHER (ABOVE) THAN NOZZLE

5-3. CCR NOZZLE, PISTON MODEL, ASSEMBLY REPAIR

This task consists of: a. Disassembly b. Repair c. Assembly d. Testing

INITIAL SET-UP:

Tools:

- Tool Kit, General Mechanics (Item 1, Appendix B)
- Body Wrench (Item 5, Appendix B)
- Piston Compression Tool (Item 7, Appendix B)
- Locking Lug Assembly Tool (Item 8, Appendix B)
- Poppet Tool (Item 9, Appendix B)
- Vise (with soft face jaws) (Item 4, Appendix B)

Materials/Parts Required:

- Rags (Item 2, Appendix F)
- Solvent (Item 1, Appendix F)
- Bushing (Item 2, Appendix J)
- Alcohol, Rubbing (Item 5, Appendix F)
- Silicone Compound (Item 3, Appendix F)
- Sealing Compound (Item 4, Appendix F)
- Piston (Item 9, Appendix J)
- Seal, Sleeve (Item 4, Appendix J)
- Seal, Wiper (Item 5, Appendix J)
- Packing, Preformed (Item 6, Appendix J)
- Seal, Teflon (Item 10, Appendix J)
- Seal (Item 11, Appendix J)
- Nut (Item 12, Appendix J)
- Packing, Preformed (Item 14, Appendix J)
- Ring, Backup (Item 13, Appendix J)

General Safety Requirements:

WARNING

- Fuels are toxic and flammable. Do not get on person or clothing. Do not use near open flame. Area should be well ventilated. Do not smoke.
- Using drycleaning solvents incorrectly can cause injury or even death.

Equipment Condition:

Nozzle removed from fuel system

a. Disassembly.

- (1) Remove dust cap and install piston compression tool in coupling end of nozzle until it latches in place. Do not remove piston compression tool until directed to do so.
- (2) Push in latch actuator (1) and move handle (2) to OPEN position.

5-3. CCR NOZZLE, PISTON MODEL, ASSEMBLY REPAIR - continued.

a. Disassembly - continued.

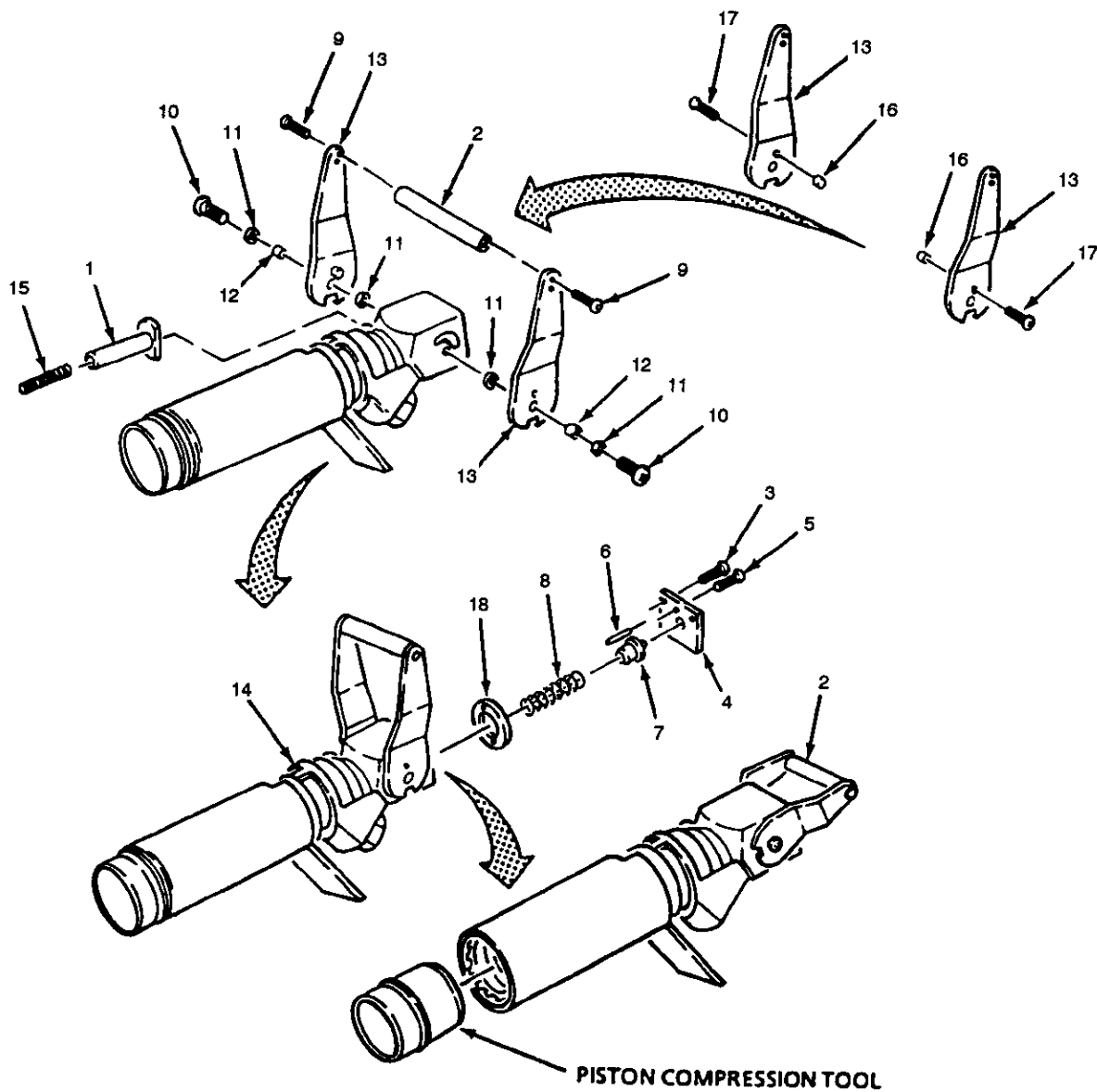

5-3. CCR NOZZLE, PISTON MODEL, ASSEMBLY REPAIR - continued.

a. Disassembly - continued.

WARNING

End cover is under spring pressure. Keep pressure on end cover while removing screws. Personal injury may occur from sudden separation of end cover.

NOTE

Removing the bonding cable assembly during repair of the CCR nozzle is optional. If removal is to be done, remove the single screw attaching the assembly to the nozzle housing.

NOTE

To remove and repair/replace CCR nozzle strainer assembly refer to chapter 4, section IV of TM 10-4930-248-13&P.

- (3) Remove four corner screws (3) and end cover (4).
- (4) Single screw (5) and lock pin (6) should not be removed unless damaged. If damaged, use a soft jaw chuck or vise to hold locking pin (6) in place and remove screw (5).
- (5) Remove spring retainer (7) and spring (8).
- (6) Remove four handle screws (9) and handle (2).
- (7) On the nozzle left side, remove screw (10), one washer (11), bushing (12) and side plate (13). Remove bushing (12) and washer (11) from screw (10). Remove second washer (11) from nozzle housing (14).
- (8) On right side of nozzle housing (14) loosen screw (10).
- (9) While compressing valve latch actuator (1) on right hand side of nozzle, remove screw (10), one washer (11), bushing (12) and side plate (13). Remove bushing (12) and washer (11) from screw (10). Remove second washer (11) from housing (14).
- (10) Slowly release valve latch actuator (1) and remove along with spring (15) from housing (14).

NOTE

Do not remove screw and actuating cam from side plate unless damaged and replacement is required.

- (11) Hold actuating cam (16) in place with a soft jawed vise and remove screw (17).
- (12) Temporarily install end cover (4) without spring (8) and spring retainer (7) in nozzle housing (14). Align lock pin (6) with one of the holes in valve actuating ring (18).
- (13) Using the poppet wrench at the coupling end of nozzle, unscrew poppet. Do not remove poppet at this time. Remove poppet wrench.

5-3. CCR NOZZLE, PISTON MODEL, ASSEMBLY REPAIR - continued.

a. Disassembly - continued.

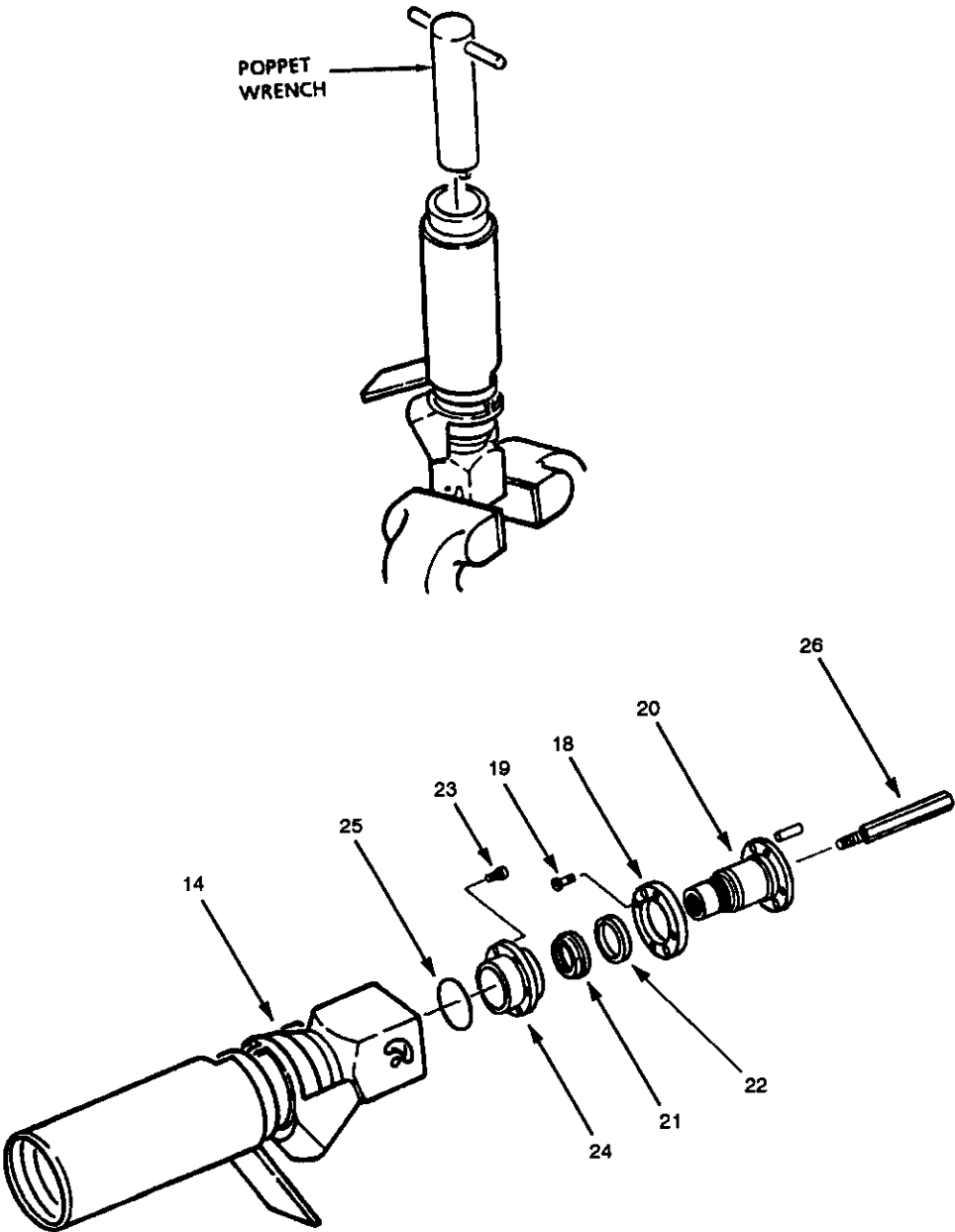

5-3. CCR NOZZLE, PISTON MODEL, ASSEMBLY REPAIR - continued.

a. Disassembly - continued.

- (14) Remove end cover (4) from housing (14).

NOTE

The piston assembly consists of the piston (20), valve actuating ring (18), seal (22) and nut (21).

- (15) Remove piston assembly from nozzle housing (14).
- (16) Remove four screws (19) attaching valve actuating ring (18) to piston (20).
- (17) Remove nut (21) and seal (22) from piston (20).
- (18) Remove screws (23) attaching sleeve (24) to nozzle housing (14), remove sleeve (24) from nozzle housing (14).
- (19) Remove preformed packing (25) from sleeve (24).

NOTE

Position indicator should only be removed if piston is to be replaced.

- (20) Remove position indicator (26).

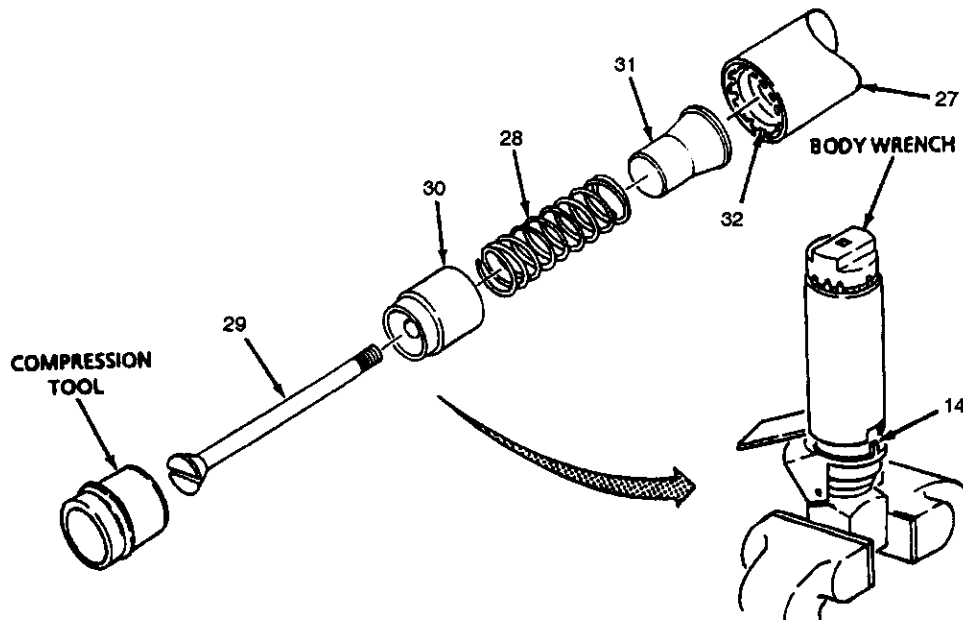

5-3. CCR NOZZLE, PISTON MODEL, ASSEMBLY REPAIR - continued.a. Disassembly - continued.

- (21) While holding the piston compression tool, slowly pull back on the collar (27). Spring (28) will push the piston compression tool, poppet (29), and sleeve seal (30) out of the nozzle housing (14).
- (22) Remove spring (28) and flow guide (31) from coupling end of nozzle housing (14).
- (23) Place nozzle housing (14) in a soft face vise with coupling end of nozzle facing up. Only tighten the vise enough to retain the nozzle housing (14).

CAUTION

Failure to trip the collar latch with the body wrench will cause damage to stayback detents.

- (24) Align body wrench with locking lugs (32) and press into coupling end of nozzle until the collar (27) trips to the forward position.

WARNING

Body and collar are under spring pressure. Maintain pressure on the body wrench to prevent sudden separation.

- (25) Turn body wrench and loosen nozzle body (33) from nozzle housing (14).
- (26) While holding collar spring (34) and collar (27) together, remove collar (27) and spring (34) from nozzle housing (14).
- (27) Place collar (27), with body wrench still attached, on a workbench with coupling end down.
- (28) Remove collar spring (34) from collar (27).
- (29) Remove spring retainer (35) and stayback spring (36) from collar (27).
- (30) Remove lug retaining ring (37), nine locking lugs (38), three stayback detents (39) and lug wire (40) from body (33).
- (31) Remove and discard wiper seal (41) from nozzle body (33).
- (32) Remove and discard backup ring (42) and teflon seal (43) from nozzle body (33).
- (33) Remove and discard preformed packing (44) from nozzle housing (14).

5-3. CCR NOZZLE, PISTON MODEL, ASSEMBLY REPAIR - continued.

a. Disassembly - continued.

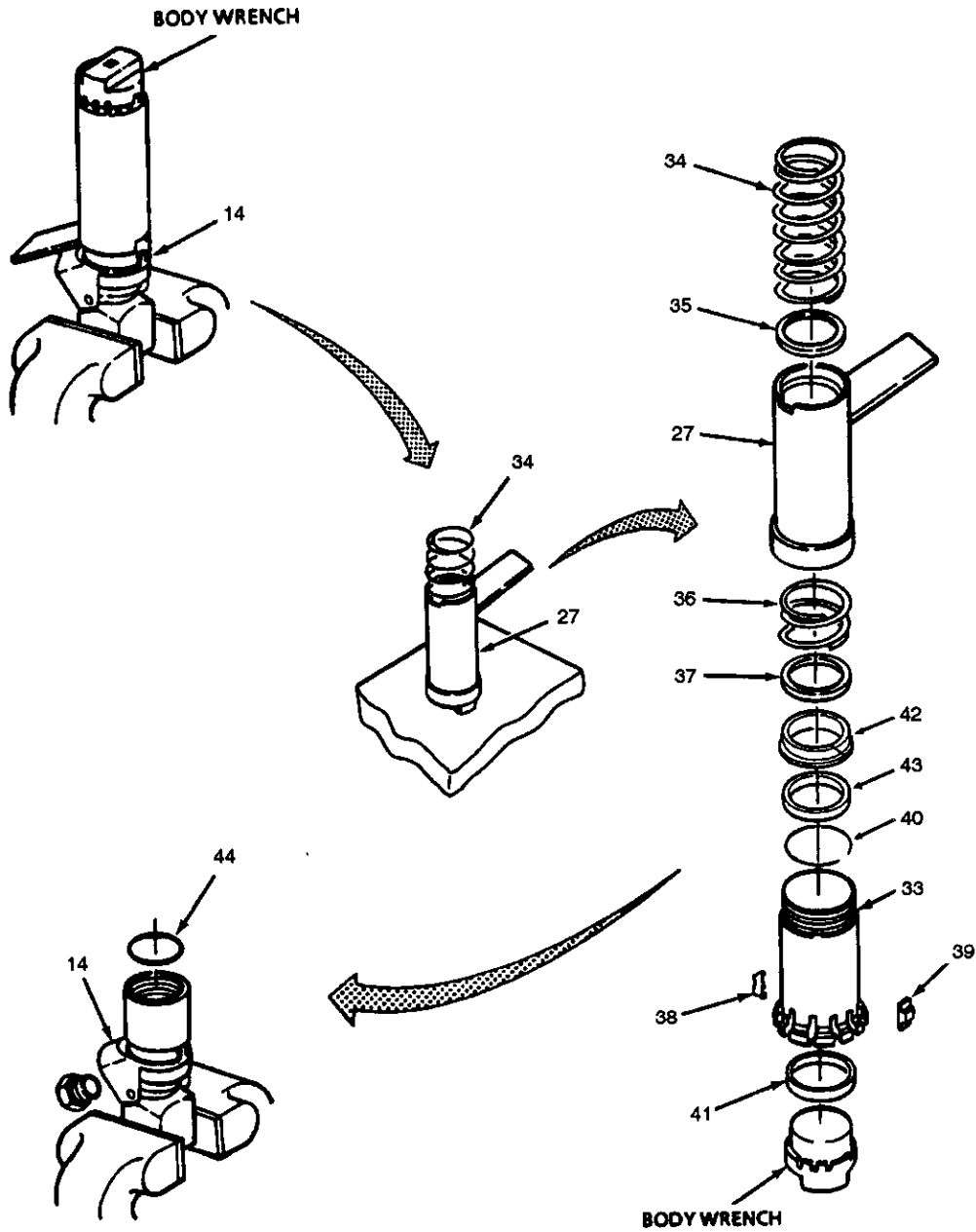

5-3. CCR NOZZLE, PISTON MODEL, ASSEMBLY REPAIR - continued.
--

b. Repair.**WARNING**

Drycleaning solvent, P-D-680 Type III, used to clean parts is potentially dangerous to personnel and property. Use in a well ventilated area as the fumes are dangerous if inhaled. Avoid repeated and prolonged skin contact. Do not use near open flame or excessive heat. Flash point of solvent is 138°F .

- (1) Clean all components removed using a wiping rag moistened with drycleaning solvent. Dry with a clean, dry wiping rag.
- (2) Inspect all parts for damage. Look for damaged threads, broken, worn, scored, or deformed parts, cracks or corrosion.
- (3) Replace damaged or defective components.

c. Assembly.

- (1) Install wiper seal (41) in coupling end of nozzle body. The open end of the "V" of wiper seal (41) must face toward the coupling end of nozzle body (33). Smooth in with a finger to assure it is properly seated in the groove.
- (2) Install teflon seal (43) in the remaining groove. Open end (spring is visible) of teflon seal (43) must face the threaded end of the nozzle body (33).
- (3) Install backup ring (42) in the inside groove closest to the threaded end of nozzle body (33). The thin lip of the backup ring (42) faces the threaded portion of the nozzle body (33).
- (4) Smooth the teflon seal (43) into place with your finger to ensure it is installed correctly.
- (5) Install lug wire (40) into lower groove on body (33) and insert body onto the lug assembly tool.

NOTE

The lug assembly tool should remain level and stable during installation of the stayback detents and locking lugs.

- (6) Place lug assembly tool in a vise.

NOTE

Stayback detents align with slots in the body and the three slots in the lug assembly tool. The detents are inserted behind the lug wire.

5-3. CCR NOZZLE, PISTON MODEL, ASSEMBLY REPAIR - continued.

c. Assembly - continued.

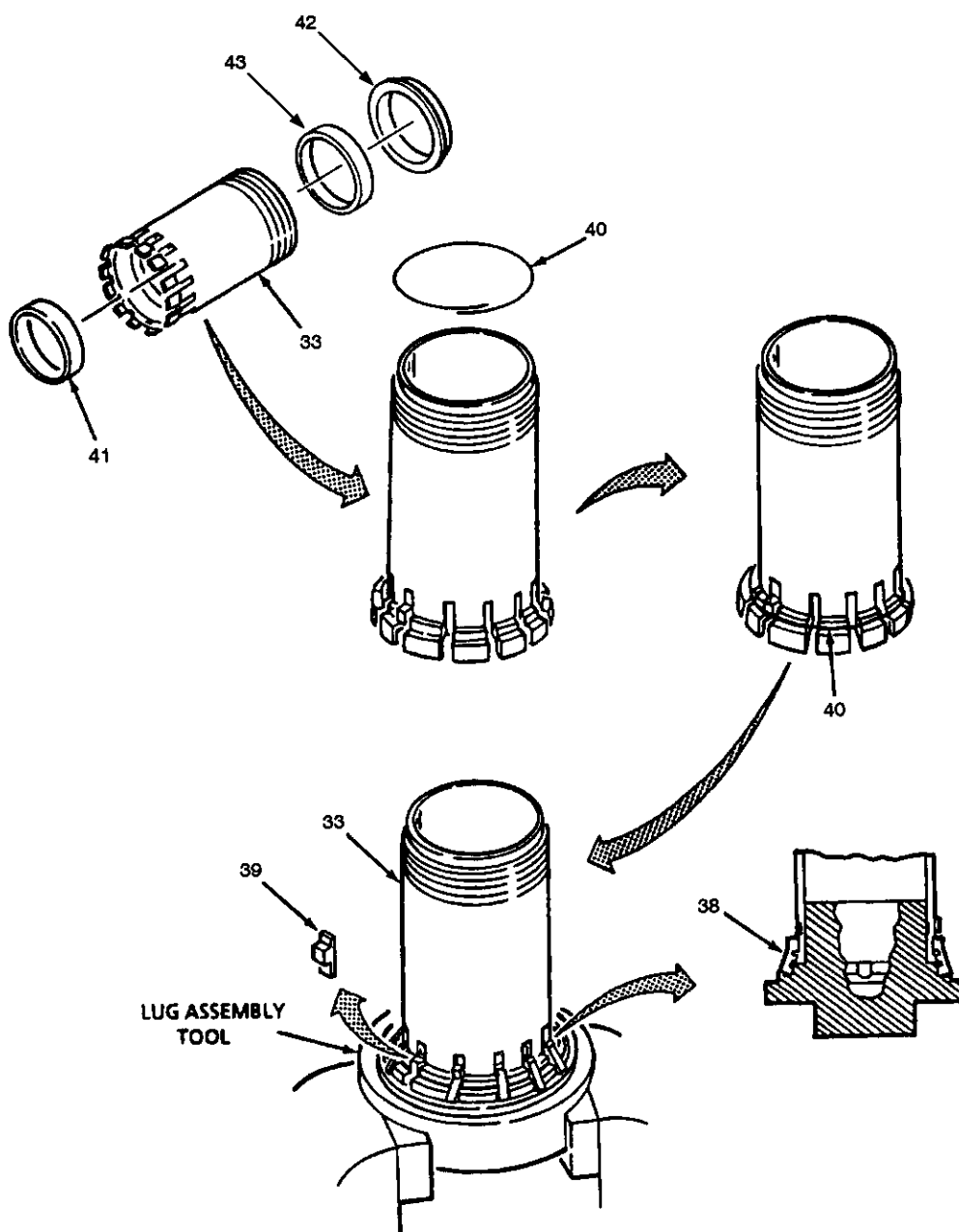

5-3. CCR NOZZLE, PISTON MODEL, ASSEMBLY REPAIR - continued.

c. Assembly - continued.

- (7) Install three stayback detents (39) on nozzle body (33).
- (8) Insert nine locking lugs (38) onto lug wire (40). Align locking lugs (38) with remaining slots in nozzle body (33).
- (9) Install lug retaining ring (37) onto nozzle body (33) with beveled end of retaining ring (37) facing locking lugs (38).

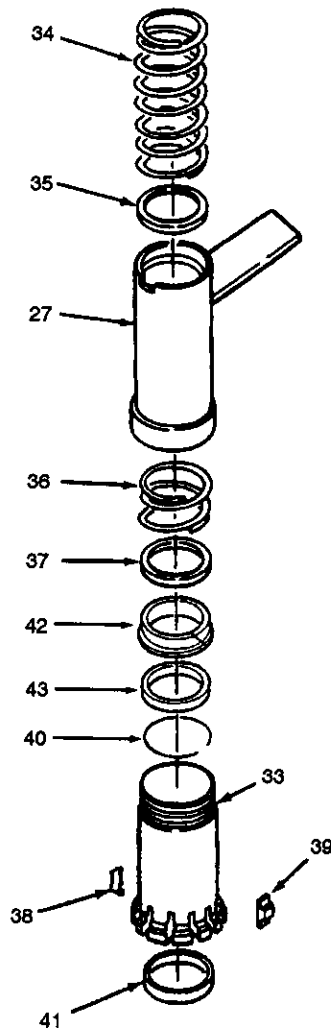

5-3. CCR NOZZLE, PISTON MODEL, ASSEMBLY REPAIR- continued.

c. Assembly - continued.

- (10) Lightly lubricate threads on nozzle body (33) with silicone compound.
- (11) Install stayback spring (36) onto nozzle body (33).
- (12) Install collar (27) over nozzle body (33), down over locking lugs (38) and stayback detents (39).
- (13) Install spring retainer (35) with groove facing down and install collar spring (34).

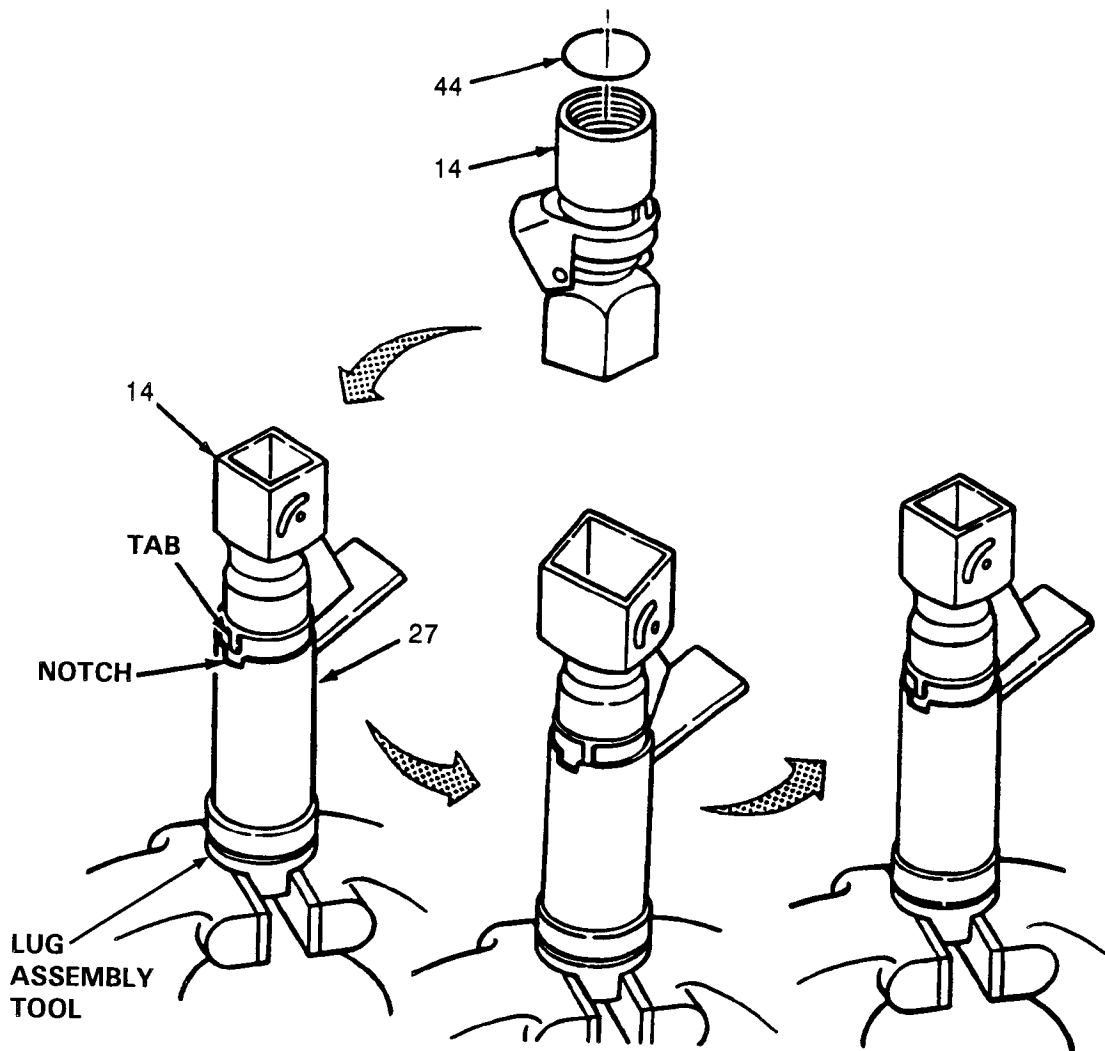

5-3. CCR NOZZLE, PISTON MODEL, ASSEMBLY REPAIR - continued.

c. Assembly - continued.

- (14) Lubricate preformed packing (44) with silicone compound and install into nozzle housing (14).
- (15) Slide nozzle housing (14) into collar (27). Align the notch on the collar (27) with tab on top of nozzle housing (14).

CAUTION

Use the lug assembly tool to tighten the body. Use the body wrench to complete the tightening process.

- (16) Push down on nozzle housing (14) and rotate clockwise until tab contacts the collar (27). Rotate housing (14) counterclockwise until notch and tab are aligned.
- (17) Remove the assembled components from lug assembly tool and remove tool from vise.
- (18) Place nozzle housing (14), with coupling end facing up, into a soft jawed vise and tighten only enough to prevent the housing from turning or falling from vise.
- (19) Align body wrench with the nine locking lugs and press the body wrench down until the collar (27) trips to the forward position.

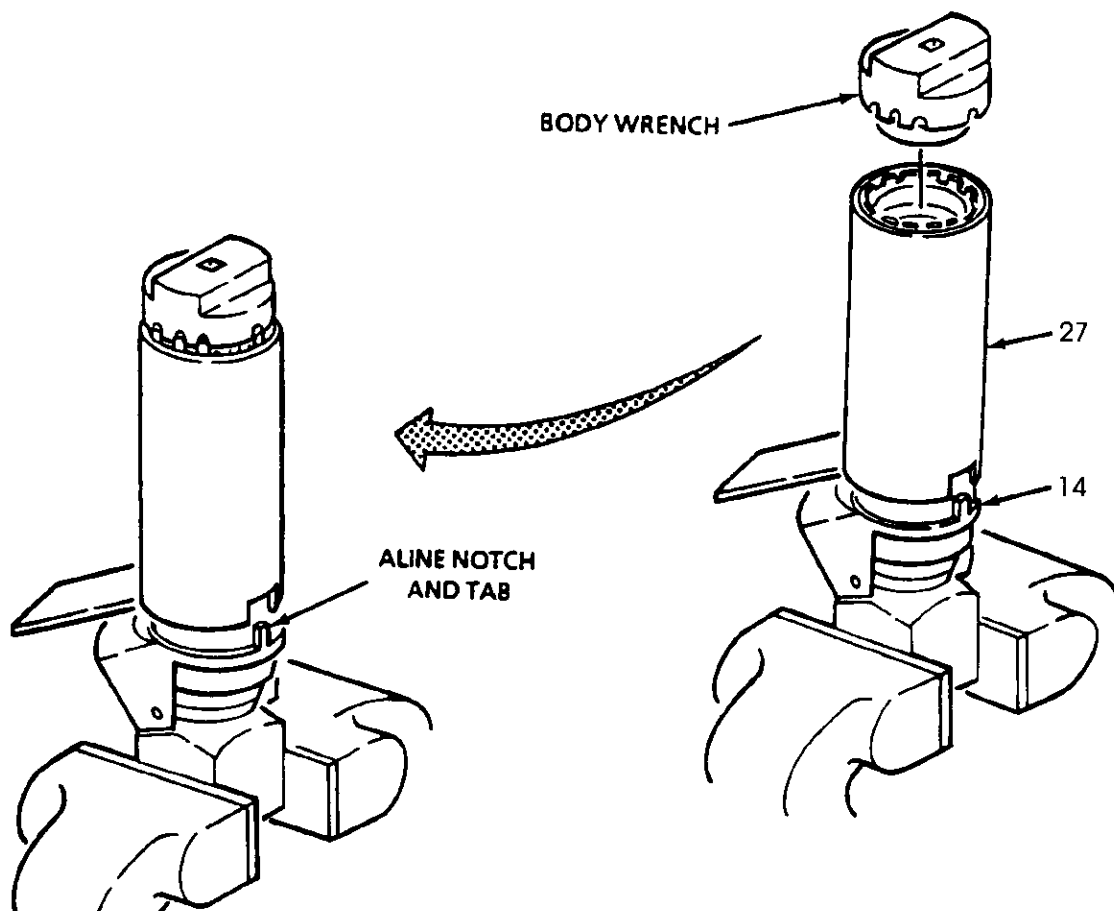

5-3. CCR NOZZLE, PISTON MODEL, ASSEMBLY REPAIR - continued.

CAUTION

To reduce the friction between locking lugs and collar, pull back slightly on the collar.

NOTE

Always align the slot in the collar and the tab on the housing.

- (20) Tighten the assembly to 250 in. lbs.
- (21) Pull back on the collar (27) to release the body wrench, remove body wrench. Remove nozzle assembly from vise.
- (22) Insert flow guide (31), spring (28) and sleeve seal (30) into nozzle housing (14).

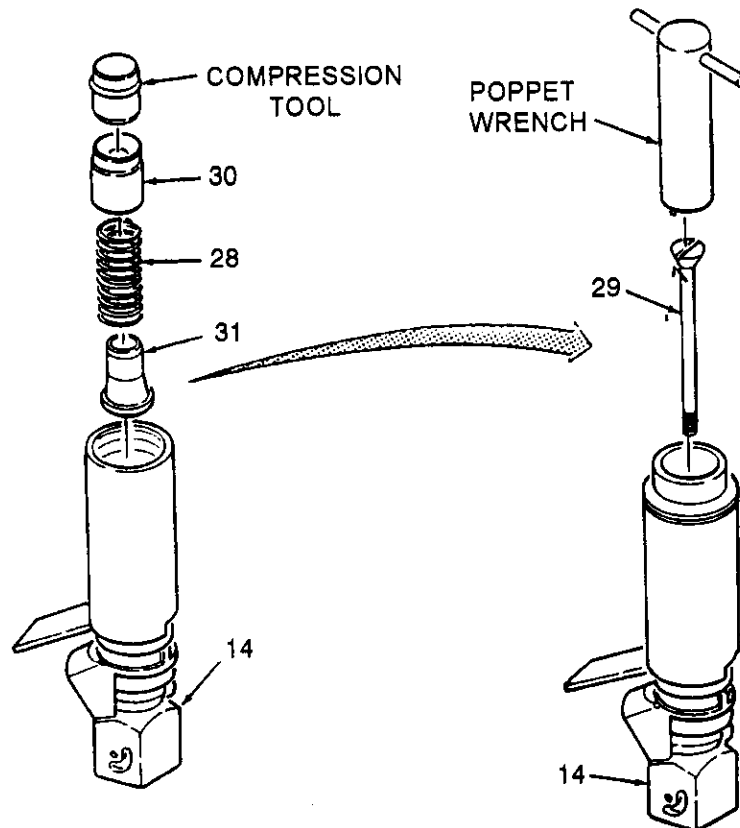

5-3. CCR NOZZLE, PISTON MODEL, ASSEMBLY REPAIR - continued.

c. Assembly - continued.

WARNING

During assembly the components; spring, flow guide and sleeve seal will be under spring pressure. Do not push or pull collar to the rear. Do not remove compression tool until assembly is completed.

- (23) Using compression tool push sleeve seal (30) and spring (28) into nozzle housing (14) until compression tool locks in collar (27).
- (24) Insert poppet (29) through compression tool into nozzle housing (14).

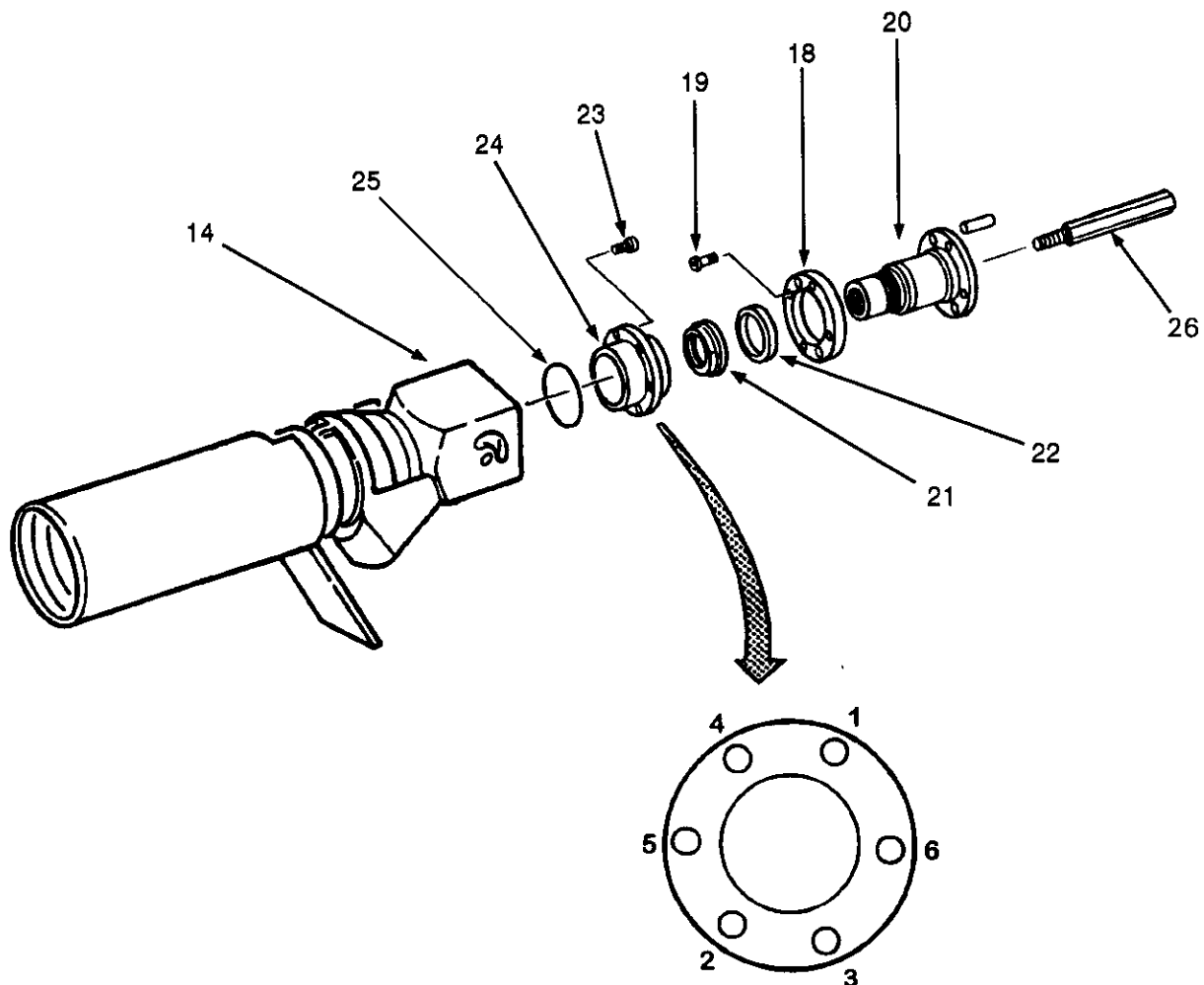

5-3. CCR NOZZLE, PISTON MODEL, ASSEMBLY REPAIR - continued.

c. Assembly - continued.

NOTE

The piston assembly consists of the piston (20), valve actuating ring (18), seal (22) and nut (21).

- (25) Install preformed packing (25) in groove on sleeve (24) and install in nozzle housing (14) using screws (23). Tighten in an "x" pattern and torque to 23 in. lbs.
- (26) Place seal (22) on threaded end of piston (20) with open end facing toward the threaded end of piston (20).
- (27) Screw nut (21) onto piston (20), torque nut (21) to 125 in. lbs.
- (28) Install valve actuating ring (18) over small end of piston (20) and attach with four screws (19). Tighten screws enough to seat the valve actuating ring (18). Do not over tighten.

CAUTION

Exercise care in installing flow indicator. Do not over tighten so as not to twist it off in the piston assembly.

- (29) If removed, screw flow indicator (26) in piston assembly.
- (30) Install piston assembly in nozzle housing (14) by threading piston assembly onto poppet (29).
- (31) If the actuating cam (16) was removed use a soft jawed vise to attach the actuating cam (16) to either side handle plate (13) with screw (17). Torque screw (17) to 100 ± 10 in. lbs. Repeat with the other side handle plate (13).
- (32) Attach side plate (13) on left side of nozzle housing (14) first. Attach side handle plate(s) (13) in to nozzle housing (14) in the open position.
- (33) Position actuating cam (16) of left hand side plate (13) into banana shaped slot in nozzle housing (14) such that actuating cam (16) is positioned between actuating ring (18) and sleeve (24).
- (34) Install washer (11) between side plate (13) and nozzle housing (14). Insert bushing (12) in side plate (13). Position a washer (11) on outside of side plate (13) and attach parts to nozzle housing (14) using screw (10). Torque screw (10) to 125 ± 10 in. lbs.
- (35) Insert spring (15) into right side of nozzle housing (14) followed by latch actuator (1).
- (36) Position actuating cam (16) of right hand side plate (13) into banana shaped slot in nozzle housing (14) such that actuating cam (16) is positioned between actuating ring (18) and sleeve (24).

5-3. CCR NOZZLE, PISTON MODEL, ASSEMBLY REPAIR - continued.

c. Assembly - continued.

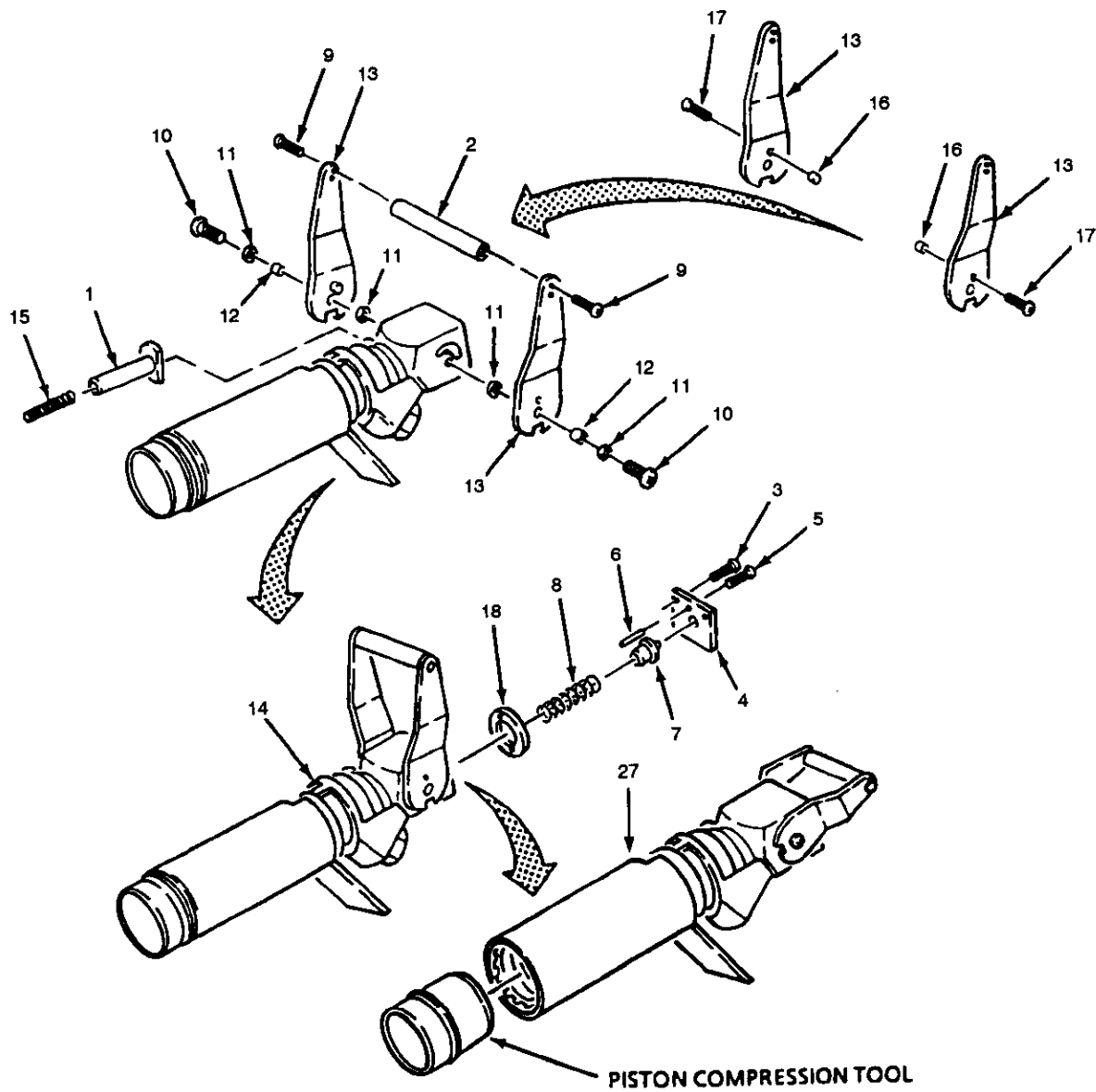

5-3. CCR NOZZLE, PISTON MODEL, ASSEMBLY REPAIR - continued.

c. Assembly - continued.

- (37) Install washer (11) between side plate (13) and nozzle housing (14). Insert bushing (12) in side plate (13). Position a washer (11) on outside of side plate (13) and attach parts to nozzle housing (14) using screw (10). Torque screw (10) to 125 ± 10 in. lbs.
- (38) Position handle (2) and install four handle screws (9). Torque handle screws (9) to 35 ± 5 in. lbs.
- (39) If screw (5) and lock pin (6) were removed from end cover (4) use a soft jaw chuck or vise to hold locking pin (6) in place and install screw (5).

NOTE

It may be necessary to reposition actuating ring (18) to allow for lock pin when installing end cover.

CAUTION

Spring pressure will be present when installing the end cover.

- (40) Position spring retainer (7) and spring (8) over position indicator.
- (41) Install end cover (4) using screws (3). Tighten screws (3).
- (42) Use poppet tool to tighten poppet securely in piston assembly in nozzle housing (14).
- (43) Remove compression tool by pulling back on collar (27).

d. Testing. After repair, the CCR Nozzle should be tested to ensure proper operation. A typical setup for testing is shown.

WARNING

Drycleaning solvent, AA 711 Types I and II, used to clean parts is potentially dangerous to personnel and property. Use in well ventilated area as the fumes are dangerous if inhaled. Avoid repeated and prolonged skin contact. Do not use near open flame or excessive heat. Flash point of solvent is 138° F.

NOTE

There shall be no evidence of leakage during flow conditions, binding, valve chatter, distortion, or requiring excessive force at connecting and disconnecting of the nozzle to the test adapter.

- (1) Functional Test.
 - (a) Position nozzle handle (1) in the CLOSED (no flow) position and connect nozzle test adapter (2) and test adapter inlet (3).
 - (b) Open valve (8).
 - (c) Adjust pump (5) to 25 psig at nozzle inlet gage (4).
 - (d) Move nozzle handle (1) to the OPEN (flow) position to start flow.
 - (e) Close valve (8). Flow indicator at back of nozzle assembly (9) should be visible, indicating flow has stopped.

5-3. CCR NOZZLE, PISTON MODEL, ASSEMBLY REPAIR - continued.

- (f) Move nozzle handle (1) to the CLOSED (no flow) position.
- (g) Open valve (8).
- (h) Increase pump (5) pressure to 65 psig at nozzle inlet gage (4).
- (i) Slowly open the nozzle (1) handle to the OPEN (flow) position.
- (j) Close valve (8). Flow indicator at back of nozzle assembly (9) should be visible, indicating flow has stopped.
- (k) Move nozzle handle (1) to the CLOSED (no flow) position.
- (l) Remove nozzle assembly (9) from test adapter outlet (2). There should be no leakage from discharge end of nozzle.
- (m) Reduce pump (5) pressure to zero psig at nozzle inlet gage (4).
- (n) Disconnect nozzle assembly (9) from test adapter inlet (3) and install dust caps.

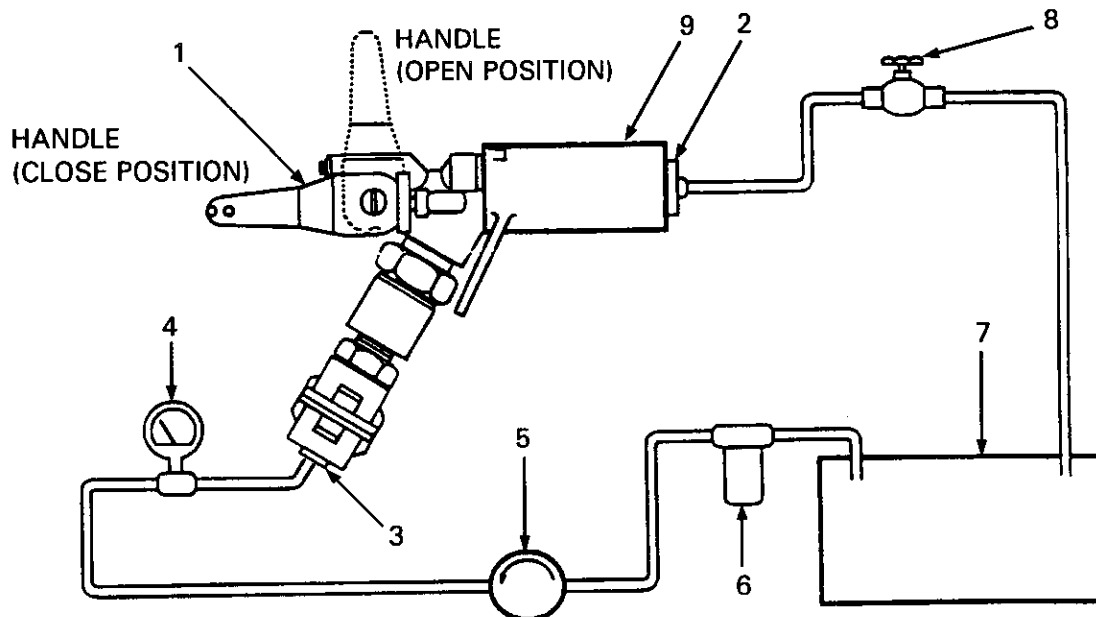

- 1. NOZZLE HANDLE
- 2. TEST ADAPTER OUTLET
- 3. TEST ADAPTER INLET
- 4. PRESSURE GAUGE, 0-300 PSIG
- 5. HYDRAULIC PUMP, 0-300 PSIG
- 6. FILTER, 15 MICRON
- 7. FLUID RESERVOIR, 10-20 GALLON
- 8. 3/4 INCH MANUAL SHUTOFF VALVE - SEE NOTE 2
- 9. NOZZLE ASSEMBLY

NOTES:

- 1. 3/4" NPT TAPPED HOLE IN BOTH ADAPTERS FOR HOSE CONNECTIONS
- 2. SHUTOFF VALVE MUST BE POSITIONED HIGHER (ABOVE) THAN NOZZLE

5-3. CCR NOZZLE, PISTON MODEL, ASSEMBLY REPAIR - continued.**WARNING**

Drycleaning solvent, P-D-680 Type III, used to clean parts is potentially dangerous to personnel and property. Use in a well ventilated area as the fumes are dangerous if inhaled. Avoid repeated and prolonged skin contact. Do not use near open flame or excessive heat. Flash point of solvent is 138°F.

NOTE

There shall be no evidence of leakage during flow conditions, binding, valve chatter, distortion, or requiring excessive force at connecting and disconnecting of the nozzle to the test adapter.

- (2) Pressure test with nozzle in the OPEN (flow) position.
 - (a) Position nozzle handle (1) in the CLOSED (no flow) position and connect nozzle assembly (9) to test adapter outlet (2) and test adapter inlet (3).
 - (b) Close valve (8) and move nozzle handle (1) to the OPEN (flow) position.
 - (c) Adjust pump (5) to 5 psig at the nozzle inlet gage (4) and maintain pressure for 1 minute maximum.
 - (d) Slowly increase pump (5) pressure to 90 psig at gage (4) and maintain pressure 1 minute minimum.
 - (e) Reduce pump (5) pressure to 20 psig and open valve (8).
 - (f) With nozzle handle (1) in the OPEN (flow) position, remove nozzle from adapter (2). There shall be no evidence of leakage from the nozzle discharge end.
 - (g) Move nozzle handle (1) to the CLOSED (no flow) position and reduce pump (5) pressure to zero.
- (3) Pressure test with nozzle in the CLOSED (no flow) position.
 - (a) Move nozzle handle (1) to the CLOSED (no flow) position.
 - (b) Disconnect Nozzle (1) from test adapter outlet (2).
 - (c) Adjust pump (5) to 5 psig at the nozzle inlet gage (4) and maintain pressure for 1 minute minimum.
 - (d) Slowly increase pump (5) pressure to 90 psig at gage (4) and maintain pressure for 1 minute minimum.
 - (e) Reduce pump pressure to zero.
 - (f) Move nozzle handle (1) to the OPEN (flow) position.
 - (g) Adjust pump (5) to 5 psig at the nozzle inlet gage (4) and maintain pressure for 1 minute minimum.
 - (h) Slowly increase pump (5) pressure to 90 psig at gage (4) and maintain pressure for 1 minute minimum.
 - (i) Reduce pump pressure to zero.
 - (j) Move nozzle handle (1) to the CLOSED (no flow) position; disconnect nozzle assembly (9) from test adapter (3) and install dust caps.

APPENDIX A

REFERENCES

A-1. Scope.

This appendix lists all forms, field manuals, technical manuals and miscellaneous publications referenced in this manual. Also listed are publications that should be consulted for additional information.

A-2. Forms.

Recommended Changes to Publications and Blank Forms	DA Form 2028
Recommended Changes to Equipment Technical Publications	DA Form 2028-2
Equipment Inspection and Maintenance Worksheet	DA For 2404
Maintenance Request	DA Form 5504
Equipment Log Assembly (Records)	DA Form 2408-9
Quality Deficiency Report	SF 368
Report of Discrepancy	SF 364

A-3. Field Manuals.

NBC Contamination Avoidance	FM 3-3
NBC Protection	FM 3-4
NBC Decontamination	FM-3-5
Organizational Maintenance of Military Petroleum Pipelines, Tanks and Related Equipment	FM 10-20
Aircraft Refueling	FM 10-68
Petroleum Supply Point Equipment and Operations	FM 10-69
Rigging, Loading and Dropping Procedures	FM 10-564
First Aid for Soldiers	FM 21-11
Basic Cold Weather Manual	FM 31-70
Northern Operations	FM 31-71

A-4. Technical Manuals.

Destruction of Army Material to Prevent Enemy Use	TM 750-244-3
Operator's, Unit and Direct Support Maintenance Manual including Repair Parts and Special Tools List for the HEMTT Tanker Aircraft Refueling System, Model HTARS100	TM 10-4930-247-13&P
Operator's and Unit Maintenance Manual including Repair Parts and Special Tools List for Advanced Aviation Forward Area Refueling System (AAFARS)	TM 10-4930-250-13&P

A-5. Miscellaneous.

The Army Maintenance Management Systems	DA PAM 738-750
Security Procedures	AR 190-11, Ar 190-13
Packing of Army Material for Shipment and Storage	AR 746-1

APPENDIX B MAINTENANCE ALLOCATION CHART

Section I. INTRODUCTION

B-1. GENERAL.

- a. This section provides a general explanation of all maintenance and repair function authorized at various maintenance categories.
- b. The Maintenance Allocation Chart (MAC) in Section II designates overall authority and responsibility for performance of maintenance functions on the identified end item or component. The application of the maintenance functions to the end item or component will be consistent with the capacities and capabilities of the designated maintenance categories.
- c. Section III lists the tools and test equipment (both special tools and common tool sets) required for each maintenance function as referenced from Section II.
- d. Section IV contains supplemental instructions and explanatory notes for a particular maintenance function.

B-2. MAINTENANCE FUNCTIONS.

Maintenance functions will be limited to and are defined as follows:

- a. Inspect. To determine the serviceability of an item by comparing its physical, mechanical, and/or electrical characteristics with established standards through examination (e.g., by sight, sound, or feel).
- b. Test. To verify serviceability by measuring the mechanical, pneumatic, hydraulic, or electrical characteristics of an item and comparing those characteristics with prescribed standards.
- c. Service. Operations required periodically to keep an item in proper operating condition, i.e., to clean (includes decontaminate, when required), to preserve, to drain, to paint, or to replenish fuel, lubricants, chemical fluids, or gases.
- d. Remove/Install. To remove and install the same item when required to perform service or other maintenance functions. Install may be the act of emplacing, seating, or fixing into position a spare, repair part, or module (component or assembly) in a manner to allow the proper functioning of an equipment or system.
- e. Replace. To remove an unserviceable item and install a serviceable counterpart in its place. "Replace" is authorized by the MAC and is shown as the 3rd position code of the SMR code.
- f. Repair. The application of maintenance services, including fault location/troubleshooting, removal/installation, and disassembly/assembly procedures, and maintenance actions to identify troubles, and restore serviceability to an item by correcting specific damage, fault, malfunction, or failure in a part, subassembly, module (component or assembly) end item, or system.

B-2. MAINTENANCE FUNCTIONS - continued.

- j. **Overhaul.** That maintenance effort (service/action) prescribed to restore an item to a completely serviceable/operational condition as required by maintenance standards in appropriate technical publications (i.e., DMWR). Overhaul is normally the highest degree of maintenance performed by the Army. Overhaul does not normally return an item to like new condition.
- k. **Rebuild.** Consists of those services/actions necessary for the restoration of unserviceable equipment to a like new condition in accordance with original manufacturing standards. Rebuild is the highest degree of material maintenance applied to Army equipment. The rebuild operation includes the act of returning to zero those age measurements (hours/miles, etc.) considered in classifying Army equipment/components.

B-3. EXPLANATION OF COLUMNS IN THE MAC - SECTION II.

- a. **Column 1, Group Number.** Column 1 lists functional group code numbers, the purpose of which is to identify maintenance significant components, assemblies, subassemblies, and modules with the next higher assembly. End item group numbers are "00".
- b. **Column 2, Component/Assembly.** Column 2 contains the names of components, assemblies, subassemblies, and modules for which maintenance is authorized.
- c. **Column 3, Maintenance Function.** Column 3 lists the functions to be performed on the item listed in Column 2. (For a detailed explanation of these functions, see paragraph B-2).
- d. **Column 4, Maintenance Level.** Column 4 specifies, by the listing of a work time figure (expressed as man-hours shown as whole hours or decimals) in the appropriate subcolumn(s), the level of maintenance authorized to perform the function listed in Column (3). This figure represents the active time required to perform that maintenance function at the indicated level of maintenance. If the number or the complexity of the tasks within the listed maintenance function vary at different maintenance levels, appropriate work time figures will be shown for each level. The work time figure represents the average time required to restore an item (assembly, subassembly, component, module, end item, or system) to a serviceable condition under typical field operating conditions. This time includes preparation item including any necessary disassembly/assembly time), troubleshooting/fault location time, and quality assurance/quality control time in addition to the time required to perform

B-3. EXPLANATION OF COLUMNS IN THE MAC - SECTION II - continued.

the specific tasks identified for the maintenance functions authorized in the maintenance allocation chart. The system designations for the various maintenance levels are shown on the following page.

- C Operator or crew
- O Unit Maintenance
- F Direct Support Maintenance
- H General Support Maintenance
- D Depot Maintenance

- e. Column 5, Tools and Equipment. Column 5 specifies, by code, those common tool sets (not individual tools) common TMDE, and special tools, special TMDE, and support equipment required to perform the designated function.
- f. Column 6, Remarks. This column, when applicable, contains a letter code, in alphabetic order, which is keyed to the remarks contained in Section IV.

B-4. EXPLANATION OF COLUMNS IN TOOL AND TEST EQUIPMENT REQUIREMENTS, SECTION III.

- a. Column 1, Reference Code. The tool and test equipment reference code correlates with a code used in the MAC, Section II, Column 5.
- b. Column 2, Maintenance Level. The lowest category of maintenance authorized to use the tool or test equipment.
- c. Column 3, Nomenclature. Name or identification of the tool or test equipment.
- d. Column 4, National Stock Number. The national stock number of the tool or test equipment.
- e. Column 5, Tool Number. The manufacturer's part number.

B-5. EXPLANATION OF COLUMNS IN REMARKS, SECTION IV.

- a. Column 1, Reference Code. The code recorded in column 6, Section II.
- b. Column 2, Remarks. This column lists information pertinent to the maintenance function being performed as indicated in the MAC, Section II.

Section II. PRELIMINARY MAINTENANCE ALLOCATION CHART

(1) GROUP NUMBER	(2) COMPONENT/ ASSEMBLY	(3) MAINTENANCE FUNCTION	(4) MAINTENANCE CATEGORY					(5) TOOLS & EQUIP.	(6) RE- MARKS
			UNIT		DS	GS	DEPOT		
			C	O	F	H	D		
00	Closed-Circuit Refueling Nozzle Assembly	INSPECT REPLACE REPAIR							
01	Closed-Circuit Refueling Nozzle Assembly	INSPECT REPLACE REPAIR	0.5	0.5 0.5	2.5			1,2 3,4,5,6,7,8, 9	A

Section III. TOOLS AND TEST EQUIPMENT REQUIREMENTS

(1) REFERENCE CODE	(2) MAINTENANCE CATEGORY	(3) NOMENCLATURE	(4) NATIONAL STOCK NUMBER (NSN)	(5) TOOL NUMBER
1	O	Tool Kit, General Mechanics	5180-00-177-7033	SC-5180-90-CL-N26
2	O	Shop Set, Automotive Vehicle	4910-00-754-0654	SC-4910-95-CL-A74
3	F	Tool Kit, General Mechanics	5180-00-699-5273	SC-5180-90-CL-N05
4	F	Shop Equipment, Automotive	4910-00-754-0705	SC-4910-95-CL-A31
5	F	Body Wrench		220281
6	F	Diaphragm Carrier Wrench		220282
7	F	Piston Compression Tool		220283
8	F	Locking Lug Assembly Tool		220284
9	F	Poppet Wrench		220329

Section IV. REMARKS

REFERENCE CODE	REMARKS
A	Repair limited to replacement of defective parts.

APPENDIX C

REPAIR PARTS AND SPECIAL TOOLS LIST

SECTION I. INTRODUCTION

C-1. SCOPE.

This RPSTL lists and authorizes spares and repair parts; special tools; special test, measurement, and diagnostic equipment (TMDE); and other special support equipment required for performance of unit, direct support, and general support maintenance of the Closed Circuit Refueling Nozzle Assembly, Model 64017B, NSN 4930-01-383-9467. It authorizes the requisitioning, issue, and disposition of spares, repair parts and special tools as indicated by the source, maintenance and recoverability (SMR) codes.

C-2. GENERAL.

In addition to this section, Introduction, this Repair Parts and Special Tools List is divided into the following sections:

a. **Section II. Repair Parts List.** A list of spares and repair parts authorized by this RPSTL for use in the performance of maintenance. This list also includes parts which must be removed for replacement of the authorized parts. Parts lists are composed of functional groups in ascending alphanumeric sequence, with the parts in each group listed in ascending figure and item number sequence. Bulk materials are listed in item name sequence. Items listed are shown on the associated Illustration(s) / (figure(s)).

b. **Section III. Special Tools List.** A list of special tools, special TMDE, and other special support equipment authorized by this RPSTL (as indicated by Basic of Issue (BOI) information in DESCRIPTION AND USABLE ON CODE column) for the performance of maintenance.

c. **Section IV. Cross-references Indexes.** A list, in National Item Identification Number (NIIN) sequence, of all National stock numbered items appearing in the listing, followed by a list in alphanumeric sequence of all part numbers appearing in the listings. National stock numbers and part numbers are cross-referenced to each illustration figure and item number appearance. The figure and item number index lists figure and item number in alphanumeric sequence and cross-references NSN, CAGEC and part number.

C-3. EXPLANATION OF COLUMNS (SECTIONS II AND III).

- a. **Item No. (Column (1)).** Indicates the number used to identify items called out in the illustration.
- b. **SMR Code (Column (2)).** The Source, Maintenance, and Recoverability (SMR) code is a 5-position code containing supply/requisitioning information, maintenance category authorization criteria, and disposition instruction, as shown in the following breakout:

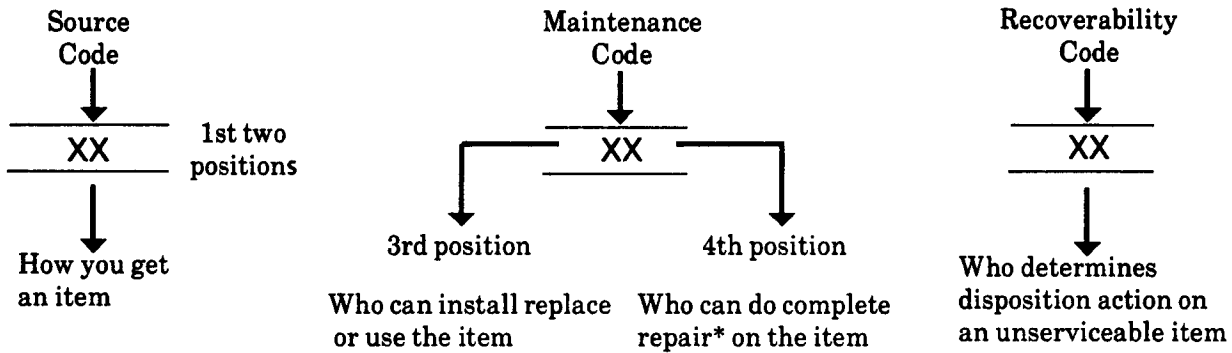

*Complete Repair: Maintenance capacity, capability, and authority to perform all corrective maintenance tasks of the "Repair" function in a use/user environment in order to restore serviceability to a failed item.

(1) **Source Code.** The source code tells you how to get an item needed for maintenance, repair, or overhaul of an end item/equipment. Explanations of source codes follows:

Source Code

Explanation

PA
PB
PC**
PD
PE
PF
PG

} Stocked items; use the applicable NSN to request/requisition items with these source codes. They are authorized to the category indicated by the code entered in the 3rd position of the SMR code.

**NOTE: Items coded PC are subject to deterioration.

KD
KF
KB

} Items with these codes are not to be requested/requisitioned individually. They are part of a kit which is authorized to the maintenance category indicated in the 3rd position of the SMR code. The complete kit must be requisitioned and applied.

MO – (Made at Unit/
AVUM Level)
MF – (Made at
DS/AVIM Level)
MH – (Made at GS
Level)
ML – (Made at
Specialized
Repair Activity
(SRA))
MD – (Made at Depot)

} Items with these codes are not to be requested/requisitioned individually. They must be made from bulk material which is identified by the part number in the DESCRIPTION and USABLE ON CODE (UOC) column and listed in the Bulk Material group of the repair parts listed in the RPSTL. If the item is authorized to you by the 3rd position code of the SMR code, but the source code indicates it is made at a higher level, order the item from the higher level of maintenance.

- AO – (Assembled by Unit/ AVUM Level)
- AF – (Assembled by DS/AVIM Level)
- AH – (Assembled at GS Category)
- AL – (Assembled by SRA)
- AD – (Assembled by Depot)



Items with these codes are not to be requested/requisitioned individually. The parts that make up the assembled item must be requisitioned or fabricated and assembled at the level of maintenance indicated by the source code. If the 3rd position code of the SMR code authorizes you to replace the item, but the source code indicates the items are assembled at a higher level, order the item from the higher level of maintenance.

- XA – Do not requisition an “XA”-coded item. Order its next higher assembly. (Also, refer to the **NOTE** below.)
- XB – If an “XB” item is not available from salvage, order it using the CAGEC and part number given.
- XC – Installation drawing, diagram, instruction sheet, field service drawing, that is identified by manufacturer’s part number.
- XD – Item is not stocked. Order an “XD”-coded item through normal supply channels using the CAGEC and part number given, if no NSN is available.

NOTE

Cannibalization or controlled exchange, when authorized, may be used as a source of supply for items with the above source codes, except for those source coded “XA” or those aircraft support items restricted by requirements of AR 750-1.

(2) **Maintenance Code.** Maintenance codes tell you the level(s) of the maintenance authorized to USE and REPAIR support items. The maintenance codes are entered in the third and fourth positions of the SMR code as follows:

(a) The maintenance code entered in the third position tells you the lowest maintenance level authorized to remove, replace, and use an item. The maintenance code entered in the third position will indicate authorization to one of the following levels of maintenance.

Maintenance

Code	Application/Explanation
C	Crew or operator maintenance done within unit/AVUM maintenance.
O	Unit level/AVUM can remove, replace, and use the item.
F	Direct support/AVIM maintenance can remove, replace, and use the item.
H	General support level can remove, replace, and use the item.
L	Specialized repair activity can remove, replace, and use the item.
D	Depot level can remove, replace, and use the item.

TM10-4930-248-13&P

(b) The maintenance code entered in the fourth position tells whether or not the item is to be repaired and identifies the lowest maintenance level with the capability to do complete repair (i. e., perform all authorized repair functions).

NOTE:

Some limited repair may be done on the item at a lower level of maintenance, if authorized by the Maintenance Allocation Chart and SMR codes.

Maintenance

Code	Application/Explanation
O	– Unit/AVUM is the lowest level that can do complete repair of the item.
F	– Direct support/AVIM is the lowest level that can do complete repair of the item.
H	– General support is the lowest level that can do complete repair of the item.
L	– Specialized repair activity is the lowest level that can do complete repair of the item.
D	– Depot is the lowest level that can do complete repair of the item.
Z	– Nonrepairable. No repair is authorized.
B	– No repair is authorized. No parts or special tools are authorized for the maintenance of a “B” coded item. However, the item may be reconditioned by adjusting, lubricating, etc., at the user level.

(3) **Recoverability Code.** Recoverability codes are assigned to items to indicate the disposition action on unserviceable items. The recoverability code is entered in the fifth position of the SMR Code as follows:

Recoverability

Code	Application/Explanation
Z	– Nonrepairable item. When unserviceable, condemn and dispose of the item at the level of maintenance shown in 3rd position of SMR Code.
O	– Repairable item. When not economically repairable, condemn and dispose of the item at unit or AVUM level.
F	– Repairable item. When uneconomically repairable, condemn and dispose of the item at the direct support or AVIM level.
H	– Repairable item. When uneconomically repairable, condemn and dispose of the item at the general support level.
D	– Repairable item. When beyond lower level repair capability, return to depot. Condemnation and disposal of item not authorized below depot level.
L	– Repairable item. Condemnation and disposal not authorized below specialized repair activity (SRA).
A	– Item requires special handling or condemnation procedures because of specific reasons (e.g., precious metal content, high dollar value, critical material, or hazardous material). Refer to appropriate manuals/directives for specific instructions.

c. **CAGEC (Column (3)).** The Commercial and Government Entity Code (CAGEC) is a 5-digit numeric code which is used to identify the manufacturer, distributor, or Government agency, etc., that supplies the item.

d. **PART NUMBER (Column (4)).** Indicates the primary number used by the manufacturer, (individual, company, firm, corporation, or Government activity), which controls the design and characteristics of the item by means of its engineering drawings, specification standards, and specification requirements to identify an item or range of items.

NOTE

When you use an NSN to requisition an item, the item you receive may have a different part number from the part ordered.

e. **DESCRIPTION AND USABLE ON CODE (UOC) (Column (5)).** This column includes the following information:

- (1) The Federal item name and, when required, a minimum description to identify the item.
- (2) Part number of bulk materials are reference in this column in the line entry to be manufactured/fabricated.
- (3) The statement "END OF FIGURE" appears just below the last item description in Column(5) for a given figure in both Section II and Section III.

f. **QTY Column (6).** The QTY (quantity per figure column) indicates the quantity of the item used in the breakout shown on the illustration figure, which is prepared for a functional group, subfunctional group, or an assembly. A "V" appearing in this column in lieu of a quantity indicates that the quantity is variable and may vary from application to application.

C-4. EXPLANATION OF COLUMNS (SECTION IV).

a. **NATIONAL STOCK NUMBER (NSN) INDEX.**

(1) **STOCK NUMBER COLUMN.** This column lists the NSN by national item identification number (NIIN) sequence. The NIIN consists of the last nine digits of the NSN, i.e..

$$\begin{array}{r} \text{NSN} \\ \hline 4930-01-XXX-XXXX \\ \hline \text{NIIN} \end{array}$$

When using this column to locate an item, ignore the first four digits of the NSN. Use the complete NSN (13 digits) when requisitioning by stock number..

(2) **FIG. Column.** This column lists the number of the figure where the item is identified/located. The figures are in numerical order in Section II and Section III.

(3) **ITEM Column.** The item number identifies the item associated with the figure listed in the adjacent FIG. column. This item is also identified by the NSN listed on the same line.

b. **PART NUMBER INDEX.** Part numbers in this index are listed by part number in ascending alphanumeric sequence (i.e., vertical arrangement of letter and number combination which places the first letter or digit of each group in order A through Z, followed by the numbers 0 through 9 and each following letter or digit in like order).

(1) **CAGEC Column.** The Commercial and Government Entity Code (CAGEC) is a 5-digit numeric code used to identify the manufacturer, distributor, or Government agency/activity that supplies the item.

(2) **PART NUMBER Column.** Indicates the primary number used by the manufacturer (individual, firm, corporation, or Government activity), which controls the design and characteristics of the item by means of its engineering drawings, specifications standards, and inspection requirements to identify an item or range of items.

(3) **STOCK NUMBER Column.** This column lists the NSN for the associated part number and manufacturer identified in the PART NUMBER and CAGEC columns to the left.

(4) **FIG. Column.** This column lists the number of the figure where the item is identified/located in Section II and Section III.

(5) **ITEM Column.** This ITEM number is that number assigned to the item as it appears in the figure referenced in adjacent figure number column.

c. **FIGURE AND ITEM NUMBER INDEX.**

(1) **Fig. Column.** This lists the number of the figure where the item is identified/located in Section II and Section III.

(2) **ITEM Column.** This item number is that number assigned to the item as its appears in the figure referenced in the adjacent number column.

(3) **STOCK NUMBER Column.** This column lists the NSN for the item.

(4) **CAGEC Column.** The Commercial and Government Entity Code (CAGEC) is a 5-digit numeric code used to identify the manufacturer, distributor, or Government agency/activity that supplies the item.

(5) **PART NUMBER Column.** Indicates the primary number used by the manufacturer (individual, firm, corporation, or Government activity), which controls the design and characteristics of the item by means of its engineering drawings, specifications, standards, and inspection requirements to identify an item or range of items.in Section II and Section III.

C-5. SPECIAL INFORMATION.

a. **USABLE ON CODE.** The usable on code appears in the lower left corner of the Description column heading. Usable on codes are shown as "UOC:.." in the Description Column (justified left) on the last line applicable item description/nomenclature. Uncoded items are applicable to all models.

b. **FABRICATION INSTRUCTIONS.** Bulks materials required to manufacture items are listed in the Bulk Material Functional Group of this RPSTL. Part number for bulk materials are also referenced in the description column of the line entry for the item to be manufactured/fabricated. Detailed fabrication instructions for items source coded are found in this manual.

c. **INDEX NUMBERS.** Items which have the BULK in the figure column will have an index number shown in the item number column. This index number is a cross-reference between the National Stock Number/Part Number Index and the bulk material list in Section II.

d. **ASSOCIATED PUBLICATIONS.** The publications listed below pertain to the Closed Circuit Refueling Nozzle Assembly, Model 64017B and its components:

<u>Publication</u>	<u>Short Title</u>
TM 10-4930-247-13&P	Operation and Maintenance of HEMTT Tanker Aircraft Refueling System with Repair Parts List
TM 10-4930-250-13&P	Operator's, Unit and Direct Support Maintenance Manual Including Repair Parts and Special Tools List for Advanced Aviation Forward Area Refueling System (AAFARS)

C-6. HOW TO LOCATE REPAIR PARTS.

a. **When National Stock Number or Part Number is NOT Known.**

- (1) **First.** Using the table of contents, determine the assembly group for subassembly group to which the item belongs. This is necessary since figures are prepared for assembly groups and subassembly groups, and listings are divided into the same groups.
- (2) **Second.** Find the figure covering the assembly group or subassembly group to which the item belongs.
- (3) **Third.** Identify the item on the figure and use the figure and item Number index to find the NSN.

b. **When National Stock Number or Part Number is Known.**

- (1) **First.** Using the National Stock Number and Part Number Indexes find the pertinent National Stock Number or Part Number. The NSN index is in National Item Identification Number (NIIN) sequence (see 4.a.). The part numbers in the Part Number index are listed in ascending alphanumeric sequence (see paragraph 4.b.). Both indexes cross-reference you to the illustration/figure and item number of the item you are looking for.
- (2) **Second.** Turn to the figure and item number, verify that the item is the one you are looking for, then locate the item number in the repair parts list for the figure.

C-7. ABBREVIATIONS.

Abbreviations used in this manual are listed in MIL-STD-12.

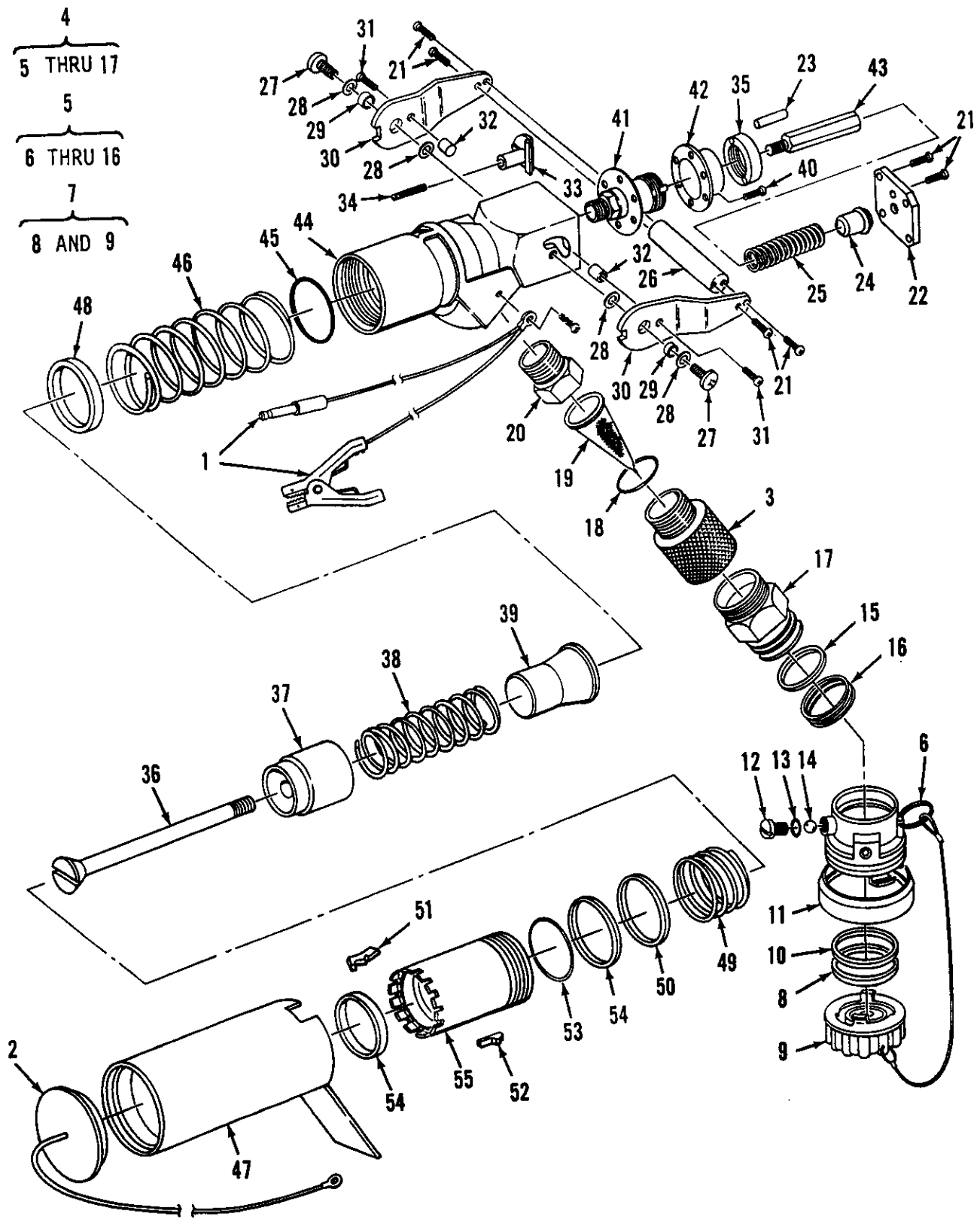

Figure 1. Nozzle Assembly (Diaphragm Activated)

SECTION II			TM10-4930-248-13&P			
(1)	(2)	(3)	(4)	(5)	(6)	
ITEM NO	SMR CODE	CAGEC	PART NUMBER	DESCRIPTION AND USABLE ON CODES(UOC)	QTY	
GROUP 01 NOZZLE ASSEMBLY						
FIG. 1 NOZZLE ASSEMBLY						
1	PAOZZ	ODT23	47028	CABLE ASSY,GROUND.....	1	
2	XBOZZ	ODT23	47025-1	CAP,ASSEMBLY,METAL.....	1	
3	XBOZZ	ODT23	220121-1	BODY,STRAINER.....	1	
4	PA000	ODT23	64019J	COUPLING,UNISEX.....	1	
5	XB000	ODT23	47032-1	.COUPLING ASSY,UNISE.....	1	
6	XBOZZ	13348	8K1	..RING,WIRE.....	1	
7	XB000	ODT23	47062	..CAP ASSY.....	1	
8	PCOZZ	ODT23	220146	...SEAL.....	1	
9	XBOZZ	ODT23	220162	...CAP.....	1	
10	PCOZZ	ODT23	220146	..SEAL.....	1	
11	XBOZZ	ODT23	220161	..BUMPER.....	1	
12	KFOZZ	96906	MS35206-276	..SCREW,MACHINE PART OF KIT P/N	1	
				47033.....		
13	PCOZZ	96906	MS29513-010	..PACKING,PREFORMED PART OF KIT P/N	1	
				47033.....		
14	KFOZZ	ODT23	220265	..BALL PART OF KIT P/N 47033.....	41	
15	KFOZZ	96906	MS29513-227	..PACKING,PREFORMED PART OF KIT P/N	1	
				47033.....		
16	KFOZZ	ODT23	220330	..SPRING,BONDING PART OF KIT P/N	1	
				47033.....		
17	XBOZZ	ODT23	220141-1	.ADAPTER,MALE.....	1	
18	PCOZZ	96906	MS29513-226	PACKING,PREFORMED PART OF KIT P/N	1	
				KD64017-2.....		
19	PBOZZ	ODT23	220122-100	STRAINER.....	1	
20	XBOZZ	ODT23	220120-1	HOUSING,STRAINER.....	1	
21	XBFZZ	ODT23	LP51958-64	SCREW,PAN HEAD.....	9	
22	XBFZZ	ODT23	220086-1	COVER,END.....	1	
23	XBFZZ	ODT23	220111	PIN,LOCK.....	1	
24	XBFZZ	ODT23	220097	RETAINER,SPRING.....	1	
25	XBFZZ	ODT23	220113	SPRING,REGULATOR.....	1	
26	XBFZZ	ODT23	220095-1	HANDLE,VALVE.....	1	
27	XBFZZ	03038	LP51957-108	SCREW,PAN HEAD.....	2	
28	XBFZZ	86928	5710-179-60	WASHER.....	4	
29	KFFZZ	ODT23	220101	BUSHING PART OF KIT P/N KD64017-2...	2	
30	XBFZZ	ODT23	220090-1	SIDE PLATE HANDLE.....	2	
31	XBFZZ	96906	MS16998-42L	SCREW,SELF-LOCKING.....	2	
32	XBFZZ	ODT23	220109	CAM,ACTUATING.....	2	
33	XBFZZ	ODT23	220202	ACTUATOR,LATCH.....	1	
34	XBFZZ	92830	C0180-026-1000S	SPRING,DETENT.....	1	
35	XBFZZ	ODT23	220098	RING,VALVE ACTUATE.....	1	
36	XBFZZ	ODT23	220088	POPPET.....	1	
37	KFFZZ	ODT23	220083-1	SLEEVE,SEAL PART OF KIT P/N KD64017-	1	
				2.....		
38	XBFZZ	ODT23	220112	SPRING,VALVE.....	1	
39	XBFZZ	ODT23	220326	GUIDE,FLOW.....	1	
40	XBFZZ	96906	MS16997-21L	SCREW,SELF-LOCKING.....	6	
41	KFFZZ	ODT23	47060-1	DIAPHRAGM ASSEMBLY PART OF KIT P/N	1	
				KD64017-2.....		

SECTION II			TM10-4930-248-13&P			
(1)	(2)	(3)	(4)	(5)	(6)	
ITEM NO	SMR CODE	CAGEC	PART NUMBER	DESCRIPTION AND USABLE ON CODES(UOC)	QTY	
42	XBFZZ	ODT23	220085	RETAINER,DIAPHRAGM.....	1	
43	XBFZZ	ODT23	220160	INDICATOR,POSITION.....	1	
44	XBFZZ	ODT23	220078-1	HOUSING.....	1	
45	KFFZZ	96906	MS29513-136	PACKING,PREFORMED PART OF KIT P/N KD64017-2.....	1	
46	XBFZZ	ODT23	220114	SPRING,COLLAR.....	1	
47	XBFZZ	ODT23	220081-1	COLLAR.....	1	
48	XBFZZ	ODT23	220096	RING,RETAINER.....	1	
49	XBFZZ	ODT23	220103	SPRING,STAY BACK.....	1	
50	XBFZZ	ODT23	220099	RING,LUG RETAINER.....	1	
51	XBFZZ	ODT23	220093	LUG,LOCKING.....	9	
52	XBFZZ	ODT23	220104	DETENT,STAY BACK.....	3	
53	XBFZZ	ODT23	220100	WIRE,LUG.....	1	
54	KFFZZ	ODT23	220094-1	SEAL,WIPER PART OF KIT P/N KD64017-2	2	
55	XBFZZ	ODT23	220080	BODY.....	1	
	PCFZZ	ODT23	KD64017-2	KIT,MAINTENANCE.....	1	
				BUSHING (2) 1-29		
				DIAPHRAGM ASSEMBLY (1) 1-41		
				PACKING,PREFORMED (1) 1-18		
				PACKING,PREFORMED (1) 1-45		
				SEAL,WIPER (2) 1-54		
				SLEEVE,SEAL (1) 1-37		
	KBOZZ	ODT23	47033	KIT,COUPLER/ADAPTER ASSY.....	1	
				BALL (41) 1-14		
				PACKING,PREFORMED (1) 1-13		
				PACKING,PREFORMED (1) 1-15		
				SCREW,MACHINE (1) 1-12		
				SPRING,BONDING (1) 1-16		

END OF FIGURE

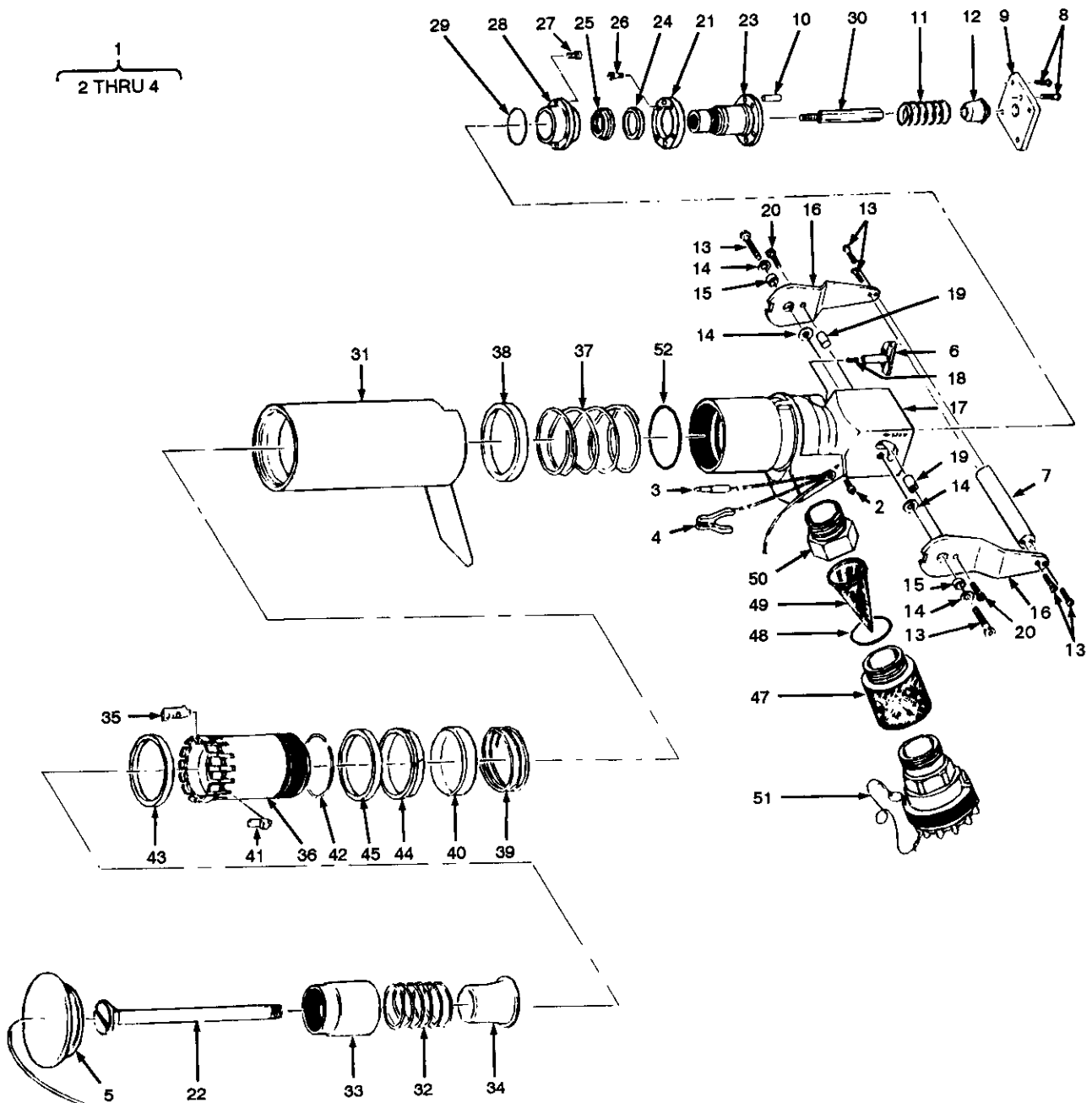

Figure 1A. Nozzle Assembly (Piston Activated)

SECTION II

TM 10-4930-248-13&P, C01

(1)	(2)	(3)	(4)	(5)	(6)
ITEM NO.	SMR CODE	CAGE	PART NUMBER	DESCRIPTION AND USABLE ON CODE (UOC)	QTY
				GROUP 02 CCR NOZZLE ASSEMBLY FIG. 1A P/N 1323OE5895	
1	PAOOO	ODT23	47028	BONDING CABLE ASSEMBLY	1
2	PAOZZ	96906	MS16998-42	.SCREW	1
3	PAOZZ	ODT23	47030	.PLUG, CABLE ASSEMBLY	1
4	PAOZZ	ODT23	47029	.CLIP, CABLE ASSEMBLY	1
5	PAOZZ	ODT23	47025-1	.DUST CAP ASSEMBLY, TAN	1
6	PAFZZ	ODT23	220202	VALVE LATCH ACTUATOR	1
7	XCFZZ	ODT23	220095-1	HANDLE, TAN	1
8	PAFZZ	03038	LP51958-64	SCREW	9
9	PAFZZ	ODT23	220086-1	END COVER, TAN	1
10	PAFZZ	ODT23	220111	LOCK PIN	1
11	PAFZZ	ODT23	220113	SPRING	1
12	PAFZZ	ODT23	220097	REDUCER SPRING RETAINER	1
13	PAFZZ	03038	LP51957-108	SCREW	2
14	PAFZZ	ODT23	5710-179-60	WASHER	4
15	KFFZZ	ODT23	220101	BUSHING	2
16	PAFZZ	ODT23	220090-1	SIDE PLATE HANDLE, TAN	2
17	XAFZZ	ODT23	220078-1	HOUSING, TAN	1
18	PAFZZ	92830	C0180-026- 1000S	SPRING	1
19	PAFZZ	ODT23	220109	ACTUATING CAM	2
20	PAFZZ	96906	MS16998-42L	SCREW	2
21	PAFZZ	ODT23	220769	VALVE ACTUATING RING	1
22	PAFZZ	ODT23	220088	POPPET	1
23	KFFZZ	ODT23	220768	PISTON	1
24	KFFZZ	ODT23	415MC-212-GC	SEAL	1
25	KFFZZ	ODT23	220777	NUT	1
26	KFFZZ	96906	MS16997-20L	SCREW	4
27	PAFZZ	96906	MS16997-21L	SCREW	6
28	KFFZZ	ODT23	220767	SLEEVE	1
29	KFOZZ	96906	MS29513-125	PACKING, PREFORMED	1
30	PAFZZ	ODT23	220160	POSITION INDICATOR	1
31	XDFZZ	ODT23	220081-1	COLLAR, TAN	1
32	PAFZZ	ODT23	220112	SPRING	1
33	PAFZZ	ODT23	220326	FLOW GUIDE	1
34	KFFZZ	ODT23	220083-1	SLEEVE SEAL	1
35	PAFZZ	ODT23	220093	LOCKING LUG	9
36	XCFZZ	ODT23	220080	BODY	1
37	PAFZZ	ODT23	220114	SPRING	1
38	PAFZZ	ODT23	220096	SPRING, RETAINER RING	1
39	PAFZZ	ODT23	220103	SPRING	1

SECTION II

TM 10-4930-248-13&P

(1) ITEM NO.	(2) SMR CODE	(3) CAGEC	(4) PART NUMBER	(5) DESCRIPTION AND USABLE ON CODE (UOC)	(6) QTY
40	PAFZZ	ODT23	220099	LUG RETAINER RING	1
41	PAFZZ	ODT23	220104	STAYBACK DETENT	3
42	PAFZZ	ODT23	220100	LUG WIRE	1
43	KFFZZ	ODT23	220094-1	WIPER SEAL	1
44	KFFZZ	ODT23	220778	RING, BACKUP	1
45	KFFZZ	ODT23	220779	SEAL, TEFLON	1
46	KFFZZ	96906	MS29513-136	PACKING, PREFORMED	1
47	XCFZZ	ODT23	220121-1	STRAINER BODY, TAN	1
48	PCOZZ	96906	MS29513 -226	PACKING, PREFORMED	1
49	PAOZZ	ODT23	220122-100	STRAINER	1
50	XCFZZ	ODT23	220120-1	STRAINER HOUSING, TAN	1
51	PAOOO	ODT23	64019J	COUPLING, UNISEX	1
SEE FIG. 1B FOR ASSEMBLY BREAKDOWN					
52	PAFZZ	ODT23	KD64017-7	KIT, REPAIR PARTS	V
				BUSHING (2) 1A-15	
				PACKING, PREFORM (1) 1A-29	
				PACKING, PREFORM (1) 1A-48	
				PACKING, PREFORM (1) 1A-46	
				RING, BACKUP (1) 1A-44	
				SEAL (1) 1A-24	
				SEAL. TEFLON (1) 1A-45	
				SLEEVE, SEAL (1) 1A-34	
				WIPER SEAL (1) 1A-43	

END OF FIGURE

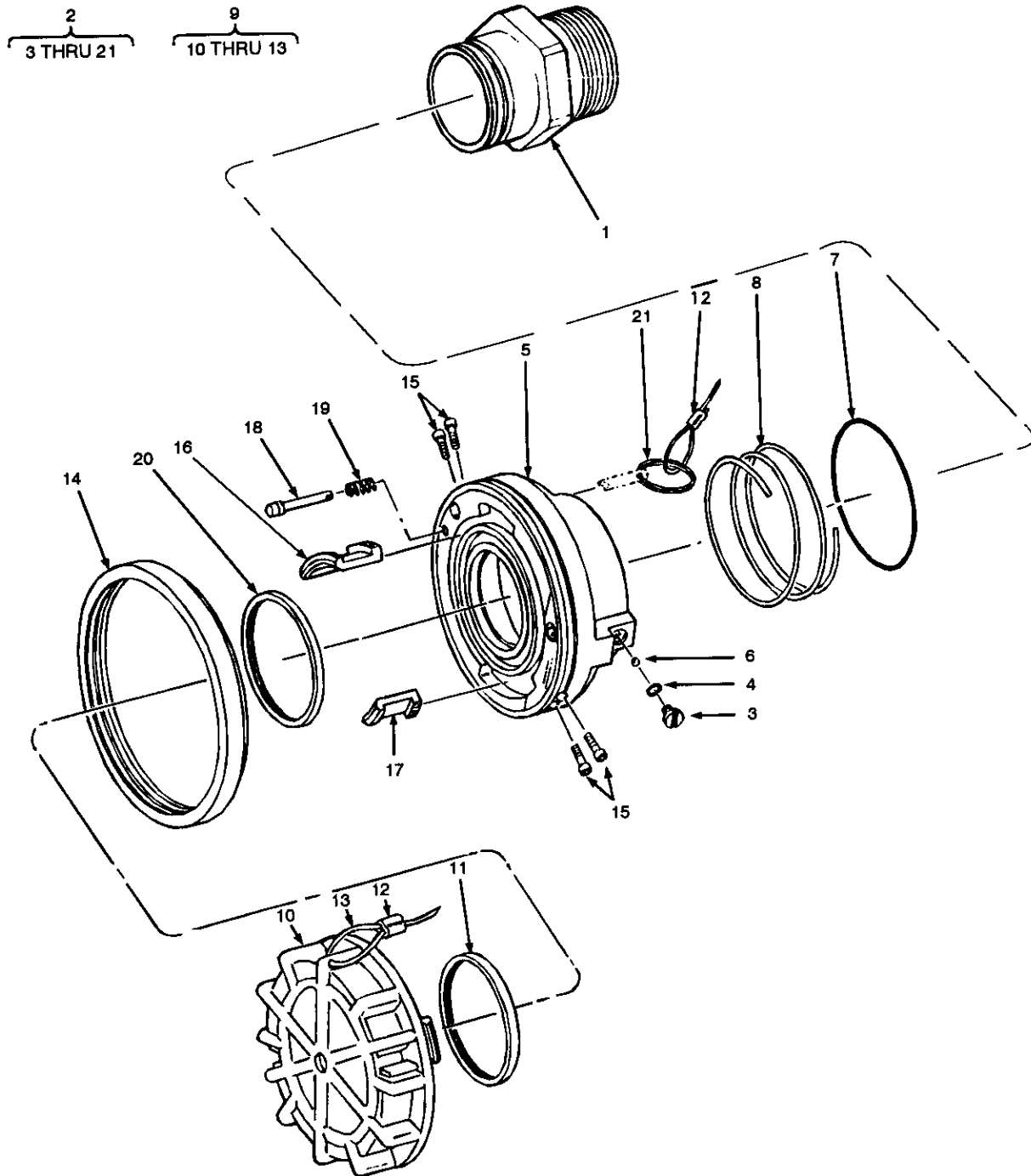

Figure 1B. Unisex Coupling, 2-Inch, Non-Valved

SECTION II

TM 10-4930-248-13&P,C01

(1) ITEM NO.	(2) SMR CODE	(3) CAGE CODE	(4) PART NUMBER	(5) DESCRIPTION AND USABLE ON CODE (UOC)	(6) QTY
				GROUP 02 CCR NOZZLE ASSEMBLY FIG. 1B UNISEX COUPLING, 2-INCH, NON-VALVED	
1	PAOZZ	ODT23	220141-2	INLET, MALE NPT, 2-INCH	1
2	XAOOO	ODT23	64019	COUPLING, UNISEX, 2", NON-VALVED	1
3	KFOZZ	96906	MS35206-276	.SCREW	1
4	PCOZZ	96906	MS29513-010	.PACKING, PREFORMED	1
5	XAOZZ	ODT23	220164-1	.BODY	1
6	PAOZZ	ODT23	220265	.BALL	41
7	KFOZZ	96906	MS29513-228	.PACKING, PREFORMED	1
8	PAOZZ	ODT23	220330	.SPRING	1
9	PAOOO	ODT23	47062	.DUST CAP ASSY	1
10	PAOZZ	ODT23	220162	..CAP	1
11	KFOZZ	ODT23	220146	..SEAL	1
12	PAOZZ	ODT23	28-2-G	..SLEEVE	1
13	PAOZZ	ODT23	220201-1-18	..CABLE	1
14	PAOZZ	ODT23	220161	.BUMPER	1
15	PAOZZ	96906	MS16997-20L	.SCREW	4
16	PAOZZ	ODT23	220159-1	.LUG, LONG	1
17	PAOZZ	ODT23	220159-2	.LUG, SHORT	1
18	PAOZZ	ODT23	220148	.PIN, LOCKOUT	1
19	PAOZZ	ODT23	220301	.SPRING	1
20	KFOZZ	ODT23	220146	.SEAL	1
21	PAOZZ	ODT23	8K1	.RING	1
22	PAFZZ	ODT23	KD64017-4	KIT, REPAIR PARTS	V
				BUSHING (2) 1A-15	
				NUT (1) 1A-25	
				PACKING, PREFORM (1) 1A-29	
				PACKING, PREFORM (1) 1A-48	
				PISTON (1) 1A-23	
				RING, BACKUP (1) 1A-44	
				SCREW, MACHINE (1) 1B-3	
				SCREW, SELF LOCK (4) 1A-26	
				SEAL (1) 1A-24	
				SEAL, PLAIN (1) 1B-11	
				SEAL, PLAIN (1) 1B-20	
				SEAL, TEFLON (1) 1A-45	
				SEAL (1) 1A-28	
				SLEEVE, SEAL (1) 1A-34	
				PACKING, PREFORM (1) 1B-7	
				PACKING, PREFORM (1) 1A-46	
				WIPER SEAL (1) 1A-43	
23	PAFZZ	ODT23	KD64019-1	KIT, REPAIR PARTS	
				SCREW, MACHINE (1) 1B-3	
				SEAL, PLAIN (1) 1B-20	
				SEAL, PLAIN (1) 1B-11	
				PACKING, PREFORM (1) 1B-7	

END OF FIGURE

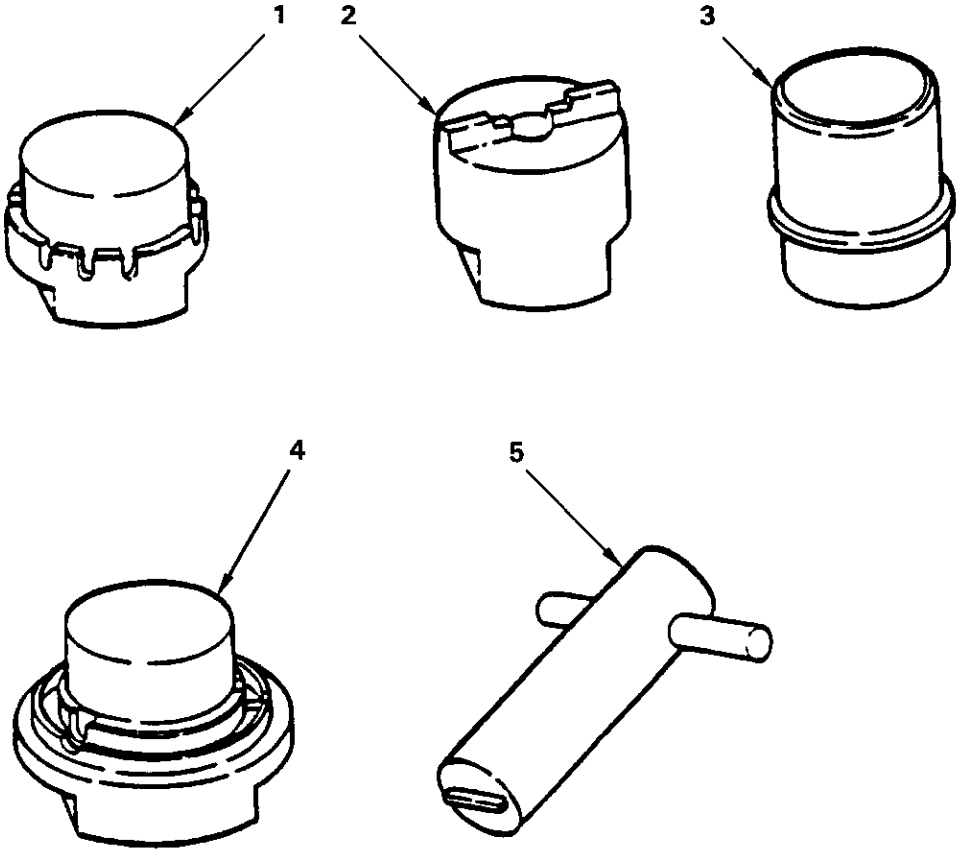

Figure 2. Special Tools

SECTION III			TM10-4930-248-13&P		
(1)	(2)	(3)	(4)	(5)	(6)
ITEM	SMR		PART		
NO	CODE	CAGEC	NUMBER	DESCRIPTION AND USABLE ON CODES(UOC)	QTY

GROUP 02 SPECIAL TOOLS

FIG. 2 SPECIAL TOOLS

1	PFFZZ	ODT23	220281	WRENCH,BODY.....	
2	PFFZZ	ODT23	220282	WRENCH,DIAPHRAGM.....	
3	PFFZZ	ODT23	220283	TOOL,PISTON COMPRES.....	
4	PFFZZ	ODT23	220284	TOOL,LOCKING LUG.....	
5	PFFZZ	ODT23	220329	POPPET WRENCH.....	

END OF FIGURE



CROSS-REFERENCE INDEXES

STOCK NUMBER	NATIONAL STOCK NUMBER INDEX		STOCK NUMBER	FIG. ITEM
	FIG.	ITEM		
5330-00-248-3835	1	13		
5330-00-263-5173	1	18		
5120-01-391-5129	2	*1		
5120-01-392-4141	2	*3		
5120-01-393-6290	2	*5		
5120-01-397-4789	2	*4		

CROSS-REFERENCE INDEXES

CAGE	PART NUMBER	PART NUMBER INDEX STOCK NUMBER	FIG.	ITEM
92830	CO180-26-1000S		1	34
ODT23	KD64017-2		1	
ODT23	KD64017-4		1B	* 22
ODT23	KD64017-7		1A	* 52
ODT23	KD64019-1		1B	* 23
03038	LP51957-108		1	27
ODT23	LP51958-64		1	21
96096	MS16997-20L		1A	* 26
96096	MS16997-21L		1	40
96906	MS16998-42		1A	* 2
96096	MS16998-42L		1	31
96096	MS29513-010	5330-00-248-3835	1	13
96906	MS29513-125		1A	* 29
96096	MS29513-136		1	45
96096	MS29513-226	5330-00-263-5173	1	18
96096	MS29513-227		1	15
96906	MS29513-228		1B	* 7
96096	MS35206-276		1	12
ODT23	220078-1		1	44
ODT23	220079		1A	* 45
ODT23	220080		1	55
ODT23	220081-1		1	47
ODT23	220083-1		1	37
ODT23	220085		1	42
ODT23	220086-1		1	22
ODT23	220088		1	36
ODT23	220090-1		1	30
ODT23	220093		1	51
ODT23	220094-1		1	54
ODT23	220095-1		1	26
ODT23	220096		1	48
ODT23	220097		1	24
ODT23	220098		1	35
ODT23	220099		1	50
ODT23	220100		1	53
ODT23	220101		1	29
ODT23	220103		1	49
ODT23	220104		1	52
ODT23	220109		1	32
ODT23	220111		1	23
ODT23	220112		1	38
ODT23	220113		1	25
ODT23	220114		1	46
ODT23	220120-1		1	20
ODT23	220121-1		1	3
ODT23	220122-100		1	19
ODT23	220141-1		1	17
ODT23	220141-2		1B	* 1
ODT23	220146		1	8
			1	10

CROSS-REFERENCE INDEXES

CAGE	PART NUMBER	PART NUMBER INDEX STOCK NUMBER	FIG.	ITEM
ODT23	220148		1B	* 18
ODT23	220159-1		1B	* 16
ODT23	220159-2		1B	* 17
ODT23	220160		1	43
ODT23	220161		1	11
ODT23	220162		1	9
ODT23	220164-1		1B	* 5
ODT23	220201-1-18		1B	* 13
ODT23	220202		1	33
ODT23	220265		1	14
ODT23	220281	5120-01-391-5129	2	1
ODT23	220282		2	2
ODT23	220283	5120-01-392-4141	2	3
ODT23	220284	5120-01-397-4789	2	4
ODT23	220301		1B	* 19
ODT23	220326		1	39
ODT23	220329	5120-01-393-6290	2	5
ODT23	220330		1	16
ODT23	220767		1A	* 28
ODT23	220768		1A	* 23
ODT23	220769		1A	* 21
ODT23	220777		1A	* 25
ODT23	220778		1A	* 44
ODT23	220779		1A	* 45
ODT23	28-2-G		1B	* 12
ODT23	415MC-212-GC		1A	* 24
ODT23	47025-1		1	1
ODT23	47028		1	5
ODT23	47029		1A	* 4
ODT23	47030		1A	* 3
ODT23	47032-1		1	
ODT23	47033		1	41
ODT23	47060-1		1	7
ODT23	47062		1	28
86928	5710-179-60		1	4
ODT23	64019		1B	* 2
ODT23	64019J		1	6
13348	8K1		1	6

CROSS-REFERENCE INDEXES

FIGURE AND ITEM NUMBER INDEXES		STOCK NUMBER		CAGEC	PART NUMBER
FIG.	ITEM				
1				ODT23	KD64017-2
1				ODT23	47033
1	1			ODT23	47028
1	2			ODT23	47025-1
1	3			ODT23	220121-1
1	4			ODT23	64019J
1	5			ODT23	47032-1
1	6			13348	8K1
1	7			ODT23	47062
1	8			ODT23	220146
1	9			ODT23	220162
1	10			ODT23	220146
1	11			ODT23	220161
1	12			96906	MS35206-276
1	13	5330-00-248-3835		96906	MS29513-010
1	14			ODT23	220265
1	15			96906	MS29513-227
1	16			ODT23	220330
1	17			ODT23	220141-1
1	18	5330-00-263-5173		96906	MS29513-226
1	19			ODT23	220122-100
1	20			ODT23	220120-1
1	21			ODT23	LP51958-64
1	22			ODT23	220086-1
1	23			ODT23	220111
1	24			ODT23	220097
1	25			ODT23	220113
1	26			ODT23	220095-1
1	27			03038	LP51957-108
1	28			86928	5710-179-60
1	29			ODT23	220101
1	30			ODT23	220090-1
1	31			96906	MS16998-42L
1	32			ODT23	220109
1	33			ODT23	220202
1	34			92830	C0180-026-1000S
1	35			ODT23	220098
1	36			ODT23	220088
1	37			ODT23	220083-1
1	38			ODT23	220112
1	39			ODT23	220326
1	40			96906	MS16997-21L
1	41			ODT23	47060-1
1	42			ODT23	220085
1	43			ODT23	220160
1	44			ODT23	220078-1
1	45			96906	MS29513-136
1	46			ODT23	220114
1	47			ODT23	220081-1
1	48			ODT23	220096
1	49			ODT23	220103

CROSS-REFERENCE INDEXES

FIG.	ITEM	FIGURE AND ITEM NUMBER STOCK NUMBER	INDEX CAGEC	PART NUMBER
1	50		ODT23	220099
1	51		ODT23	220093
1	52		ODT23	220104
1	53		ODT23	220100
1	54		ODT23	220094-1
1	55		ODT23	220080
1A	*2		ODT23	MS16998-42
1A	*3		ODT23	47030
1A	*4		ODT23	47029
1A	*21		ODT23	220769
1A	*23		ODT23	220768
1A	*24		ODT23	415MC-212-GC
1A	*25		ODT23	220777
1A	*26		96096	MS16997-20L
1A	*28		ODT23	220767
1A	*29		96906	MS29513-125
1A	*44		ODT23	220778
1A	*45		ODT23	220779
1A	*52		ODT23	KD64017-7
1B	*1		ODT23	220141-2
1B	*2		ODT23	64019
1B	*5		ODT23	220164-1
1B	*7		96906	MS29513-228
1B	*12		ODT23	28-2-G
1B	*13		ODT23	220201-1-18
1B	*16		ODT23	220159-1
1B	*17		ODT23	220159-2
1B	*18		ODT23	220148
1B	*19		ODT23	220301
1B	*22		ODT23	KD64017-4
1B	*23		ODT23	KD64019-1
2	1	5120-01-391-5129	ODT23	220281
2	2		ODT23	220282
2	3	5120-01-392-4141	ODT23	220383
2	4	5120-01-397-4789	ODT23	220284
2	5	5120-01-393-6290	ODT23	220329

APPENDIX D

COMPONENTS OF END ITEM AND BASIC ISSUE ITEMS LIST

Section I. INTRODUCTION

D-1. SCOPE.

This appendix lists components of end item and basic issue items for the CCR Nozzle to help you inventory items required for safe and efficient operation.

D-2. GENERAL.

The Components of End Item and Basic Issue Items List are divided into the following sections:

- a. Section II. Components of End Item. This listing is for informational purposes only, and is not authority to requisition replacements. These items are part of the end item, but are removed and separately packaged for transportation or shipment. As part of the end item, these items must be with the end item whenever it is issued or transferred between property accounts. Illustrations are furnished to assist you in identifying the items.
- b. Section III. Basic Issue Items. These are the minimum essential items required to place the CCR Nozzle in operation, to operate it, and to perform emergency repairs. Although shipped separately packaged, BII must be with the CCR Nozzle during operation and whenever it is transferred between property accounts. The illustrations will assist you with hard-to-identify items. This manual is your authority to request/requisition replacement BII, based on TOE/MTOE authorization of the end item.

D-3. EXPLANATION OF COLUMNS.

The following provides an explanation of columns found in the tabular listing:

- a. ITEM NUMBER Column. This column indicates the number of the illustration in which the item is shown.
- b. NATIONAL STOCK NUMBER Column. Indicates the national stock number assigned to the item and will be used for requisitioning purposes.
- c. DESCRIPTION, CAGE CODE AND PART NUMBER Column. Indicates the Federal item and name and, if required, a minimum description to identify and locate the item. The last line for each item indicates the CAGE Code (in parentheses) followed by the part number.
- d. UNIT OF ISSUE (U/I) Column. Indicates the measure used in performing the actual operational/maintenance function. This measure is expressed by a two-character alphabetical abbreviation (e.g., ea, in, pr).
- e. QUANTITY REQUIRED (QTY REQD) Column. Indicates the quantity of the item authorized to be used with/on the equipment.

Section II. COMPONENTS OF END ITEM

(NOT APPLICABLE)

Section III. BASIC ISSUE ITEMS

ITEM NUMBER	NATIONAL STOCK NUMBER	DESCRIPTION CAGE CODE AND PART NUMBER	U/I	QTY REQD
1		Operator's Unit, and Direct Support Maintenance Manual Including Repair Parts and Special Tools List TM 10-4930-248-13&P	EA	1

TM 10-4930-248-13&P

TECHNICAL MANUAL

OPERATOR'S, UNIT, AND DIRECT SUPPORT MAINTENANCE MANUAL INCLUDING REPAIR PARTS AND SPECIAL TOOLS LIST

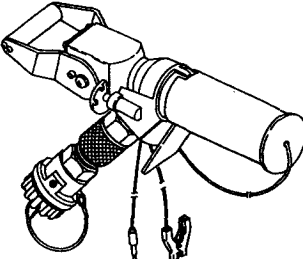

**CLOSED-CIRCUIT REFUELING NOZZLE ASSEMBLY
MODEL 64017B
(NSN: 4930-01-383-9467)**

OPERATING INSTRUCTIONS	2-1
UNIT MAINTENANCE	4-1
UNIT TROUBLESHOOTING	4-2
DIRECT SUPPORT MAINTENANCE	5-1
DIRECT SUPPORT TROUBLESHOOTING	5-1

Distribution Statement A. Approved for public release; distribution is unlimited.

HEADQUARTERS, DEPARTMENT OF THE ARMY

APPENDIX E

ADDITIONAL AUTHORIZATION LIST

Section I. Introduction.

E-1. SCOPE.

This appendix lists additional items you are authorized for the support of the CCR Nozzle.

E-2. GENERAL.

This list identifies items that do not have to accompany the CCR Nozzle and Adapter and that do not have to be turned in with it. These items are all authorized authorized to you by CTA, MTOE, TDA, or JTA.

E-3. EXPLANATION OF LISTING.

National stock number, descriptions and quantities are provided to help you identify and request the additional items you require to support this equipment. The items are listed in alphabetical sequence by item name. If the item you require differs between serial numbers of the same model, effective serial numbers are shown in the last line of the description. If item required differs for different models of this equipment, the model is shown under the "Usable on" heading in the description column.

Section II. Additional Authorization Items List

There are no additional items authorized to support the CCR nozzle.

APPENDIX F

EXPENDABLE AND DURABLE ITEMS LIST

Section I. INTRODUCTION

F-1. SCOPE.

This appendix lists expendable/durable supplies and materials you will need to operate and maintain the Closed-Circuit Refueling Nozzle. This listing is for informational purposes only and is not authority to requisition the listed items. These items are authorized to you by CTA 50-970, Expendable and Durable Items (Except Medical, Class V, Repair Parts and Heraldic Items), or CTA 8-100, Army Medical Department Expendable/Durable Items.

F-2. EXPLANATION OF COLUMNS.

- a. Column 1 - Item Number. This number is assigned to the entry in the listing and is referenced in the task Initial Setup instructions to identify the material; e.g., "Drycleaning solvent (App F, Item 1)."
- b. Column 2 - Category. This column identifies the lowest category of maintenance that requires the listed item:
 - C - Operator/Crew
 - O - Unit Maintenance
 - F - Direct Support Maintenance
 - G - General Support Maintenance
- c. Column 3 - National Stock Number. This is the national stock number assigned to the item; use it to request or requisition the items.
- d. Column 4 - Description. Indicates the federal item name and, if required, a description to identify the item. The last line for each item indicates the part number followed by the Commercial and Government Entity (CAGE) code for the Manufacturer in parentheses, if applicable.
- e. Column 5 - Unit of Measure (U/M). Indicates the measure used in performing the actual maintenance function. This measure is expressed by a two character alphabetical abbreviation (e.g., ea, in, pr). If the unit of measure differs from the rest of the issue, requisition the lowest unit of issue that will satisfy your requirements.

Section II. EXPENDABLE AND DURABLE ITEMS LIST

Item Number	Category	National Stock Number	Description	U/M
1	O	6850-00-331-3349	Cleaning Solvent, Federal Specification P-D-680, Type III	GL
2	O	7920-00-295-1711	Rags, Wiping (58536) A-A-531	LB
3	O	9150-00-119-9291	Silicone Compound (81349) MIL-G-4343	TU
4	O	8030-01-837-5885	Sealing Compound (77247) MIL-S-45180	TU
5	F	6505-00-655-8366	Alcohol, Rubbing (1DZ38) Isopropyl Rubbing Alcohol	BT
6	O	9150-00-250-0926	Petrolatum VV-P-236	LB

APPENDIX G
LUBRICATION INSTRUCTIONS

NOT APPLICABLE

No lubrication of the CCR Nozzle is required.

APPENDIX H
ILLUSTRATED LIST OF MANUFACTURED ITEMS

There are no manufactured items for the CCR Nozzle.

APPENDIX I TORQUE LIMITS

TYPE	MIN TENSILE STRNGN	MATERIAL	BODY SIZE OR OUTSIDE DIAMETER OF FASTENER													
			7/8	1	1 1/8	1 1/4	1 3/8	1 1/2	1 5/8	1 3/4	1 7/8	2	2 1/4	2 1/2	2 3/4	3
SAE 0-1-2	74,000 PSI	LOW CARBON STEEL	206	210	460	675	900	1100	1470	1900	2360	2750	3450	4400	7350	9500
SAE 3	100,000 PSI	MEDIUM CARBON STEEL	372	551	872	1211	1624	1943	2660	3463	4695	5427	7226	8049	13450	17548
SAE 5	120,000 PSI	MEDIUM CARBON HEAT TREAT STEEL	382	587	794	1105	1500	1775	2425	3150	4200	4550	6550	7175	13000	16000
SAE 6	133,000 PSI	MEDIUM CARBON STEEL QUENCHED TEMPERED	550	825	1304	1815	2434	2913	3985	5189	6980	7491	10825	14983	20151	26286
SAE 7	133,000 PSI	MEDIUM CARBON STEEL	570	840	1325	1825	2500	3000	4000	5300	7000	7500	11000	15500	21000	27000
SAE 8	150,000 PSI	MEDIUM CARBON ALLOY STEEL	600	900	1430	1975	2650	3200	4400	5650	7600	8200	12000	17000	23000	29000
SOCKET HEAD CAP SCREW	160,000 PSI	HIGH CARBON CASE HARDENED STEEL	640	970	1520	2130	2850	3450	4700	6100	8200	8800	13000	18000	24000	31000
SOCKET SET SCREW	212,000 PSI	HIGH CARBON CASE HARDENED STEEL														
MACHINE SCREW YELLOW BRASS	60,000 PSI	COPPER (CU) 63% ZINC (ZU) 37%	160	215	325	400		595								
SILICONE BRONZE TYPE "B"	70,000 PSI	COPPER (CU) 96.96% ZINC (ZNI) 2% SILICON (SI) 2%	180	250	365	450		655								

APPENDIX I
TORQUE LIMITS - continued

TYPE	MIN TENSILE STRNGN	MATERIAL	BODY SIZE OR OUTSIDE DIAMETER OF FASTENER															
			2	3	4	5	6	8	10	1/4	1/10	1/8	1/16	1/2	5/16	3/8	3/4	
SAE 0-1-2	74,000 PSI	LOW CARBON STEEL									6	12	20	32	47	69	99	155
SAE 3	100,000 PSI	MEDIUM CARBON STEEL									9	17	30	47	69	103	145	234
SAE 5	120,000 PSI	MEDIUM CARBON HEAT TREAT STEEL									10	19	33	54	78	114	154	257
SAE 6	133,000 PSI	MEDIUM CARBON STEEL QUENCHED TEMPERED									12.5	24	43	69	106	150	209	350
SAE 7	133,000 PSI	MEDIUM CARBON STEEL									13	25	44	71	110	154	215	360
SAE 8	150,000 PSI	MEDIUM CARBON ALLOY STEEL									14	29	47	78	119	169	230	380
SOCKET HEAD CAP SCREW	160,000 PSI	HIGH CARBON CASE HARDENED STEEL									16	33	54	84	125	180	250	400
SOCKET SET SCREW	212,000 PSI	HIGH CARBON CASE HARDENED STEEL						9*	16*	30*	70*	140*	18	29	43	63	100	146
MACHINE SCREW YELLOW BRASS	60,000 PSI	COPPER (CU) 63% ZINC (ZU) 37%	2*	3.3*	4.4*	6.4*	8*	16*	20*	65*	110*	17	27	37	49	78	104	
SILICONE BRONZE TYPE "B"	70,000 PSI	COPPER (CU) 96.96% ZINC (ZNI) 2% SILICON (SI) 2%	2.3**	3.7*	4.9*	7.2*	10*	19*	22*	70*	125*	20	30	41	53	88	117	

TORQUE VALUES: All figures are foot-pounds except those marked with an asterisk (*), which are inch-pounds. There is no difference in the above chart between torque figures for fine or coarse threads. The torque figure for finely-threaded fasteners as compared to coarse-threaded fasteners of the same diameter may be slightly higher, but hardly worth mentioning.

APPENDIX J

MANDATORY REPLACEMENT PARTS

ITEM No.	NOMENCLATURE	PART NUMBER
1	Packing, Preformed	MS29513-226
2	Bushing	220101
3	Diaphragm Assembly	47060-1
4	Seal, Sleeve	220083-1
5	Seal, Wiper	220094-1
6	Packing, Preformed	MS29513-136
7	Bumper, Coupling	220161
8	Gasket, Coupling, Unisex	220146
9	Piston	220768
10	Seal, Teflon	220779
11	Seal	415MC-212-GC
12	Nut	220777
13	Ring, Backup	220778
14	Packing, Preformed	MS29513-125
15	Packing, Preformed	MS29513-010
16	Packing, Preformed	MS29513-228

GLOSSARY

Section I. ABBREVIATIONS

App	Appendix
BT	Bottle
CCR	Closed-Circuit Refueling
°F	Degrees Fahrenheit
GL	Gallon
in lb	Inch Pounds
in	Inch
lb	Pound
PN	Part Number
psig	Pound-force per Square Inch, Gage
TU	Tube
para	Paragraph

Section II. DEFINITIONS OF UNUSUAL TERMS

Packing: O-Ring seals.

INDEX

SUBJECT, PARAGRAPH

SUBJECT, PARAGRAPH

-A-

Abbreviations, Glossary 1
 Additional Authorization List, E-1
 Administrative Storage, 4-13
 Assembly and Preparation for Use, 2-8

-B-

Basic Issue Items, C-3

-C-

CCR Nozzle Repair, 4-10, 5-2
 CCR Nozzle, Piston Model, Repair, 5-3
 Characteristics, Capabilities and Features, 1-10
 Checks and Services, Preventive Maintenance, 4-4
 Common Tools and Equipment, 4-1
 Components of End Item and Basic Issue Items List,
 D-1
 Corrosion Prevention and Control, 1-4
 Coupling, Unisex, Repair, 4-10B
 Coupling, Unisex, Replace, 4-10A
 Cover, 1-11
 Cross Reference List, Nomenclature, 1-7

-D-

Decals and Instruction Plates, 2-10
 Decontamination Procedures, NBC, 2-13
 Description of Major Components, 1-4
 Destruction of Army Materiel to Prevent Enemy Use,
 1-3
 Dimensions, 1-12

-E-

Emergency Procedures, 2-12
 Equipment Characteristics, Capabilities and Features,
 1-10
 Equipment Data, 1-12
 Equipment Improvement Recommendations, Reporting,
 1-5
 Expendable and Durable Items List, F-1
 Extreme Heat, Operating In, 2-11

-F-

Forms and Records, Maintenance, 1-2

-G-

General Information, 1-12
 Glossary, Glossary 1

-H-

Handle Assembly, 1-11
 How To Use Manual, iii

-I-

Illustrated List of Manufactured Items, H-1
 Instruction Plates, and Decals, 2-10

-J-

-K-

-L-

Leakage Criteria, 2-6
 List of Abbreviations, Glossary 1
 Location and Description of Major Components, 1-11

-M-

Maintenance Allocation Chart, B-1
 Maintenance Forms and Records, 1-2
 Maintenance Functions, B-2
 Maintenance, Unit, 4-7
 Mandatory Replacement Parts, H-1
 Movement, Preparation for, 4-12

INDEX - continued

SUBJECT, PARAGRAPH

SUBJECT, PARAGRAPH

-N-

Nomenclature Cross Reference List, 1-7
 Nozzle Housing, 1-11
 Nozzle Collar, 1-11
 Nuclear, Biological and Chemical (NBC)
 Decontamination Procedures, 2-13

-O-

Operating Procedures, 2-9
 Operating Temperature Range, 1-12
 Operating Under Unusual Conditions, 2-11
 Operator Preventive Maintenance Checks and Services,
 2-4
 Operator Troubleshooting, 3-1
 Operator Troubleshooting Introduction, 3-1

-P-

Parts, Repair, 4-3
 Personnel Safety, 4-8
 PMCS, 4-4
 Preparation for Movement, 4-12
 Prevention and Control, Corrosion, 1-4
 Preventive Maintenance Checks and Services, 4-4
 Proper Equipment, 4-9
 Principles of Operation, 1-13

-Q-

-R-

References, A-1
 Repair, CCR Nozzle, 4-10, 5-2
 Repair, CCR Nozzle, Piston Model, 5-3
 Repair Parts, 4-3
 Repair Unisex Coupling, 4-10B
 Replace Unisex Coupling, 4-10A
 Reporting Equipment Improvement Recommendations,
 1-5

-S-

Safety, Personnel, 4-8
 Sandy or Susty Conditions, Operating In, 2-11
 Scope, 1-1
 Security Procedures, 4-11
 Special Tools, TMDE, and Support Equipment, 4-2
 Strong Winds, Operating In, 2-11
 System Technical Principles of Operation, 1-13

-T-

Temperature Range, Operating, 1-11
 Tools and Test Equipment Requirements, B-5
 Troubleshooting, 3-3, 4-6

-U-

Unisex Coupling, Repair, 4-10B
 Unisex Coupling, Replace, 4-10A
 Unit Maintenance Procedures, 4-7
 Unit Troubleshooting Procedures, 4-6
 Unusual Conditions, Operation Under, 2-11
 Usual Conditions, Operation Under, 2-9
 Unit Troubleshooting Introduction, 4-5

-V-

-W-

Warnings, a
 Weight, 1-12

-X-

-Y-

-Z-

By Order of the Secretary of the Army:

Official:

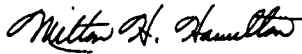
MILTON H. HAMILTON
*Administrative Assistant to the
Secretary of the Army*

06483

GORDON R. SULLIVAN
*General, United States Army
Chief of Staff*

DISTRIBUTION:

To be distributed in accordance with DA Form 12-25-E, block no. 6126, requirement for
TM 10-4930-248-13&P

RECOMMENDED CHANGES TO EQUIPMENT TECHNICAL PUBLICATIONS



THEN... JOT DOWN THE DOPE ABOUT IT ON THIS FORM. CAREFULLY TEAR IT OUT. FOLD IT AND DROP IT IN THE MAIL!

SOMETHING WRONG WITH THIS PUBLICATION?

FROM: (PRINT YOUR UNIT'S COMPLETE ADDRESS)

PFC JOHN DOE
COA, 3d ENGINEER BN
FT. BRANFORDWOOD, MA 03108

DATE SENT

PUBLICATION NUMBER
TM 10-4930-248-13&P

PUBLICATION DATE
28 Feb 94

PUBLICATION TITLE
CLOSED-CIRCUIT REFUELING NOZZLE

BE EXACT. PIN-POINT WHERE IT IS

PAGE NO	PARA-GRAPH	FIGURE NO	TABLE NO
6	2-1 a		
B1		4-3	
125	line 20		

IN THIS SPACE TELL WHAT IS WRONG AND WHAT SHOULD BE DONE ABOUT IT:

In line 6 of paragraph 2-1a the manual states the engine has 6 cylinders. The engine on my set only has 4 cylinders. Change the manual to show 4 cylinders

figure 4-3 is a bolt. In key 4-3, item 16 is called rim - Please correct or the other.

I ordered a gasket, item 19 on figure B-16 by NSN 2 910-00-762-3001. I got a gasket but it doesn't fit. Supply says I got what I ordered, so the NSN is wrong. Please give me a good NSN

PRINTED NAME, GRADE OR TITLE, AND TELEPHONE NUMBER

JOHN DOE, PFC (268) 317-7111

SIGN HERE

JOHN DOE

TEAR ALONG PERFORATED LINE

RECOMMENDED CHANGES TO EQUIPMENT TECHNICAL PUBLICATIONS



THEN... JOT DOWN THE DOPE ABOUT IT ON THIS FORM, CAREFULLY TEAR IT OUT, FOLD IT AND DROP IT IN THE MAIL!

SOMETHING WRONG WITH THIS PUBLICATION?

FROM: (PRINT YOUR UNIT'S COMPLETE ADDRESS)

DATE SENT

PUBLICATION NUMBER TM 10-4930-248-13&P	PUBLICATION DATE 28 Feb 94	PUBLICATION TITLE CLOSED-CIRCUIT REFUELING NOZZLE
--	--------------------------------------	---

BE EXACT PIN-POINT WHERE IT IS				IN THIS SPACE, TELL WHAT IS WRONG AND WHAT SHOULD BE DONE ABOUT IT:
PAGE NO	PARA-GRAPH	FIGURE NO	TABLE NO	

PRINTED NAME, GRADE OR TITLE, AND TELEPHONE NUMBER	SIGN HERE
---	------------------

DA FORM 2028-2
1 JUL 79

PREVIOUS EDITIONS ARE OBSOLETE.
DRSTS-M verprint2, 1 Nov 80

P.S. - IF YOUR OUTFIT WANTS TO KNOW ABOUT YOUR RECOMMENDATION, MAKE A CARBON COPY OF THIS AND GIVE TO YOUR HEADQUARTERS.

FILL IN YOUR
UNIT'S ADDRESS



FOLD BACK

DEPARTMENT OF THE ARMY



OFFICIAL BUSINESS

NO POSTAGE
NECESSARY
IF MAILED
IN THE
UNITED STATES

BUSINESS REPLY MAIL
FIRST CLASS BRM PERMIT NO. 82 ROCK ISLAND, IL

POSTAGE WILL BE PAID BY ROCK ISLAND ARSENAL

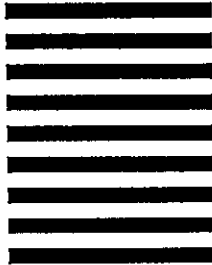

Director
Armament and Chemical Acquisition
and Logistics Activity
ATTN: AMSTA-AC-NML
ROCK ISLAND, IL 61201-9948

TEAR ALONG PERFORATED LINE



FILL IN YOUR
UNIT'S ADDRESS



FOLD BACK

DEPARTMENT OF THE ARMY



OFFICIAL BUSINESS

NO POSTAGE
NECESSARY
IF MAILED
IN THE
UNITED STATES

BUSINESS REPLY MAIL
FIRST CLASS BRM PERMIT NO. 82 ROCK ISLAND, IL

POSTAGE WILL BE PAID BY ROCK ISLAND ARSENAL

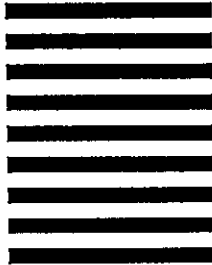

Director
Armament and Chemical Acquisition
and Logistics Activity
ATTN: AMSTA-AC-NML
ROCK ISLAND, IL 61201-9948

TEAR ALONG PERFORATED LINE



FILL IN YOUR
UNIT'S ADDRESS



FOLD BACK

DEPARTMENT OF THE ARMY



OFFICIAL BUSINESS

NO POSTAGE
NECESSARY
IF MAILED
IN THE
UNITED STATES

BUSINESS REPLY MAIL
FIRST CLASS BRM PERMIT NO. 82 ROCK ISLAND, IL

POSTAGE WILL BE PAID BY ROCK ISLAND ARSENAL

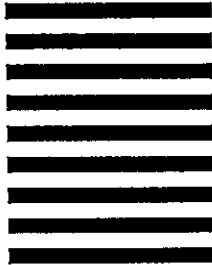

Director
Armament and Chemical Acquisition
and Logistics Activity
ATTN: AMSTA-AC-NML
ROCK ISLAND, IL 61201-9948

TEAR ALONG PERFORATED LINE



The Metric System and Equivalents

Linear Measure

1 centimeter = 10 millimeters = .39 inch
 1 decimeter = 10 centimeters = 3.94 inches
 1 meter = 10 decimeters = 39.37 inches
 1 dekameter = 10 meters = 32.8 feet
 1 hectometer = 10 dekameters = 328.08 feet
 1 kilometer = 10 hectometers = 3,280.8 feet

Weights

1 centigram = 10 milligrams = .15 grain
 1 decigram = 10 centigrams = 1.54 grains
 1 gram = 10 decigrams = .035 ounce
 1 dekagram = 10 grams = .35 ounce
 1 hectogram = 10 dekagrams = 3.52 ounces
 1 kilogram = 10 hectograms = 2.2 pounds
 1 quintal = 100 kilograms = 220.46 pounds
 1 metric ton = 10 quintals = 1.1 short tons

Liquid Measure

1 centiliter = 10 milliliters = .34 fl. ounce
 1 deciliter = 10 centiliters = 3.38 fl. ounces
 1 liter = 10 deciliters = 33.81 fl. ounces
 1 dekaliter = 10 liters = 2.64 gallons
 1 hectoliter = 10 dekaliters = 26.42 gallons
 1 kiloliter = 10 hectoliters = 264.18 gallons

Square Measure

1 sq. centimeter = 100 sq. millimeters = .155 sq. inch
 1 sq. decimeter = 100 sq. centimeters = 15.5 sq. inches
 1 sq. meter (centare) = 100 sq. decimeters = 10.76 sq. feet
 1 sq. dekameter (are) = 100 sq. meters = 1,076.4 sq. feet
 1 sq. hectometer (hectare) = 100 sq. dekameters = 2.47 acres
 1 sq. kilometer = 100 sq. hectometers = .386 sq. mile

Cubic Measure

1 cu. centimeter = 1000 cu. millimeters = .06 cu. inch
 1 cu. decimeter = 1000 cu. centimeters = 61.02 cu. inches
 1 cu. meter = 1000 cu. decimeters = 35.31 cu. feet

Approximate Conversion Factors

To change	To	Multiply by	To change	To	Multiply by
inches	centimeters	2.540	ounce-inches	newton-meters	.007062
feet	meters	.305	centimeters	inches	.394
yards	meters	.914	meters	feet	3.280
miles	kilometers	1.609	meters	yards	1.094
square inches	square centimeters	6.451	kilometers	miles	.621
square feet	square meters	.093	square centimeters	square inches	.155
square yards	square meters	.836	square meters	square feet	10.764
square miles	square kilometers	2.590	square meters	square yards	1.196
acres	square hectometers	.405	square kilometers	square miles	.386
cubic feet	cubic meters	.028	square hectometers	acres	2.471
cubic yards	cubic meters	.765	cubic meters	cubic feet	35.315
fluid ounces	milliliters	29.573	cubic meters	cubic yards	1.308
pints	liters	.473	milliliters	fluid ounces	.034
quarts	liters	.946	liters	pints	2.113
gallons	liters	3.785	liters	quarts	1.057
ounces	grams	28.349	liters	gallons	.264
pounds	kilograms	.454	grams	ounces	.035
short tons	metric tons	.907	kilograms	pounds	2.205
pound-feet	newton-meters	1.356	metric tons	short tons	1.102
pound-inches	newton-meters	.11296			

Temperature (Exact)

°F	Fahrenheit temperature	5/9 (after subtracting 32)	Celsius temperature
----	------------------------	----------------------------	---------------------

PIN: 072324-001